



« 1994 Mark VIII Table of Contents »

«Group 03: ENGINE»

«Section 03-01: Engine, 4.6L»

«DISASSEMBLY AND ASSEMBLY»

Engine

SPECIAL SERVICE TOOL(S) REQUIRED

| Description | Tool Number |
|-----------------------------|--------------|
| Crankshaft Damper Remover | T58P-6316-D |
| Cylinder Ridge Reamer | T64P-6011-EA |
| Piston and Rod Guide Tool | T93P-6136-A |
| O-Ring Remover Tool | T71P-19703-C |
| Rear Seal Installer Adapter | T82L-6701-A |
| Rear Main Seal Installer | T82L-6701-A |
| Crankshaft Damper Replacer | T74P-6316-B |

Disassembly

NOTE:

This procedure will disassemble and assemble a complete engine assembly. Only perform the necessary steps to access the particular component being serviced.

1. Remove engine as outlined.
2. Loosen four bolts retaining water pump pulley to water pump (do not remove bolts).
3. Release drive belt tensioner and remove drive belt. Refer to «Section 03-05».
4. Disconnect chassis vacuum supply hose from intake manifold connector and position out of the way.
5. Remove two retaining nuts from air cleaner outlet tube support bracket and remove bracket.
6. Disconnect water bypass tube to water thermostat housing hose at water bypass tube and remove hose and water thermostat housing assembly.
7. Disconnect A/C compressor wiring harness connection.
8. Remove three bolts retaining A/C compressor to cylinder block and remove A/C compressor.

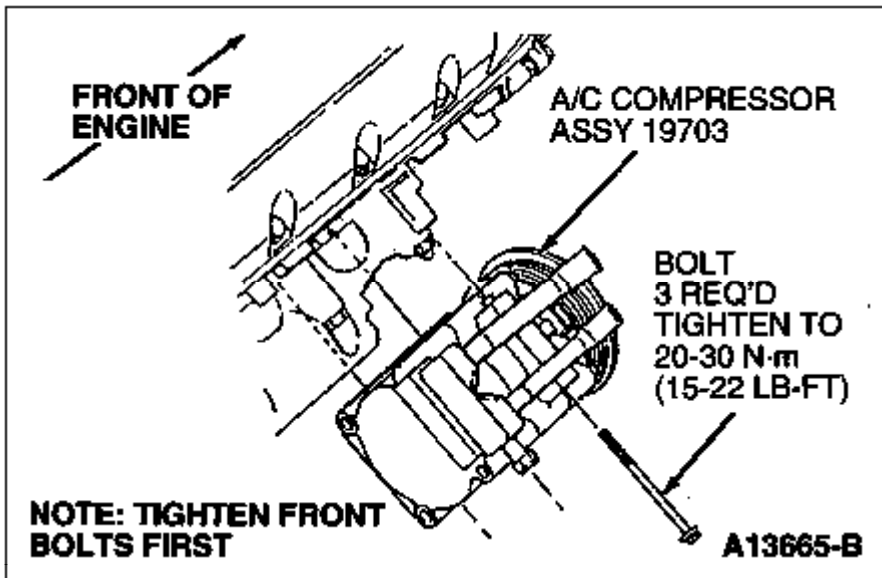

9. Remove two retaining nuts from the EGR control valve bracket and vacuum hose clip. Position control valve bracket out of the way.
10. Remove chassis vacuum hose and bracket.
11. Remove eight retaining nuts on RH and LH ignition wire covers and remove ignition wire covers.

CAUTION:

Do not pull on ignition wires.

12. Disconnect ignition wires from spark plugs with a gentle twist/pull motion on the ignition wire boot.
13. Disconnect all ignition wires from both ignition coils.
14. Detach two center ignition wire separators from generator mounting bracket.

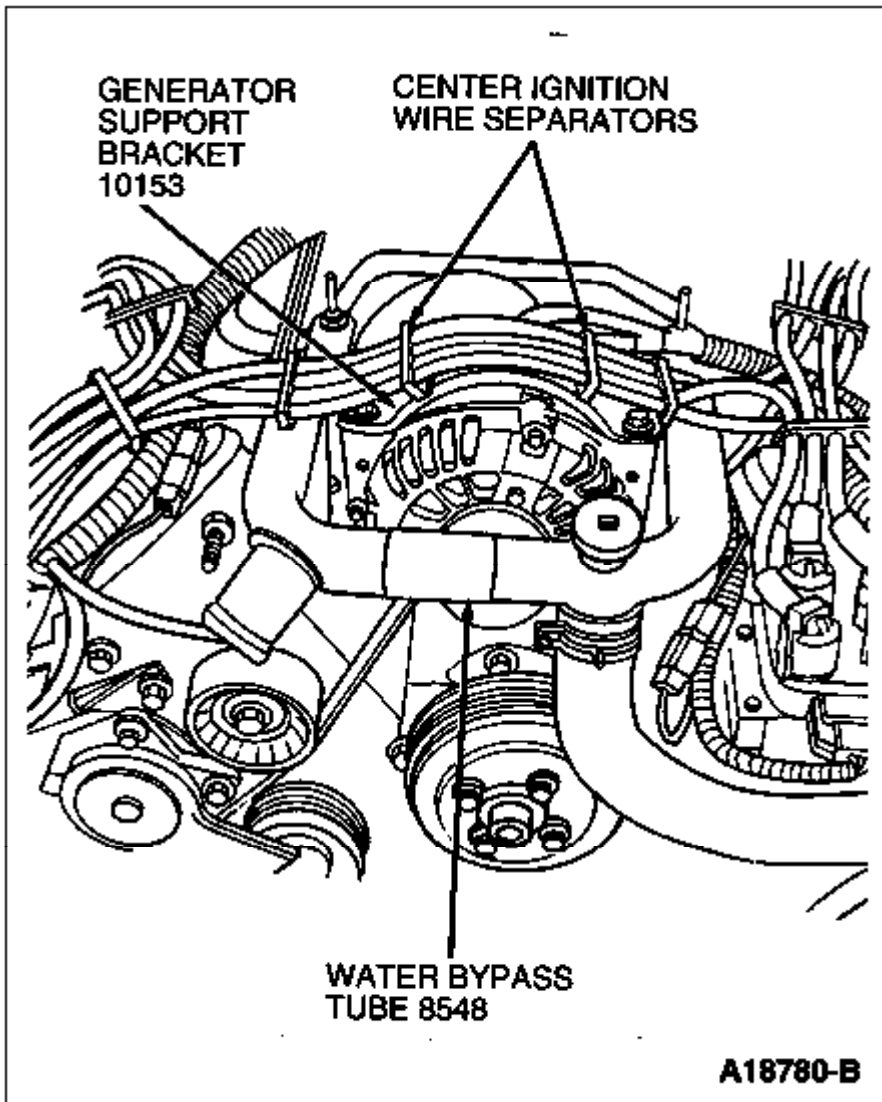

15. Remove ignition wire assembly.
16. Disconnect generator wiring harness from generator at B+ terminal and disconnect stator connector plug. Disconnect wiring harness retaining clip from generator mounting bracket.
17. Remove two bolts and two stud bolts attaching generator mounting bracket to generator and intake manifold. Remove generator mounting bracket.
18. Remove four loosened water pump pulley bolts and remove water pump pulley.
19. Disconnect engine wiring harness connector from power steering pump.
20. Remove four bolts retaining power steering pump to engine front cover and cylinder block.
21. Disconnect both engine coolant temperature sensor (ECT sensor) and water temperature indicator sender unit connections at bottom of water bypass tube.
22. Remove two retaining nuts from water bypass tube hold-down braces to intake manifold studs and remove water bypass tube.
23. Remove two bolts retaining generator to cylinder block and remove generator.
24. Disconnect wiring harness from DPFE sensor. Remove two bolts retaining DPFE sensor bracket to rear of LH cylinder head and remove bracket.
25. Remove one nut and two bolts retaining heater water hose to rear of RH cylinder head and remove heater water hose.
26. Disconnect vacuum harness from fuel pressure regulator , RH and LH intake manifold runner

control (IMRC) vacuum controls, EGR control valve, EGR vacuum regulator control and IMRC vacuum control solenoids, and intake manifold connection. Remove vacuum harness.

27. Remove positive crankcase ventilation valve and crankcase ventilation tube assembly from LH valve cover and disconnect from throttle body. Remove crankcase vent connector and hose assembly.

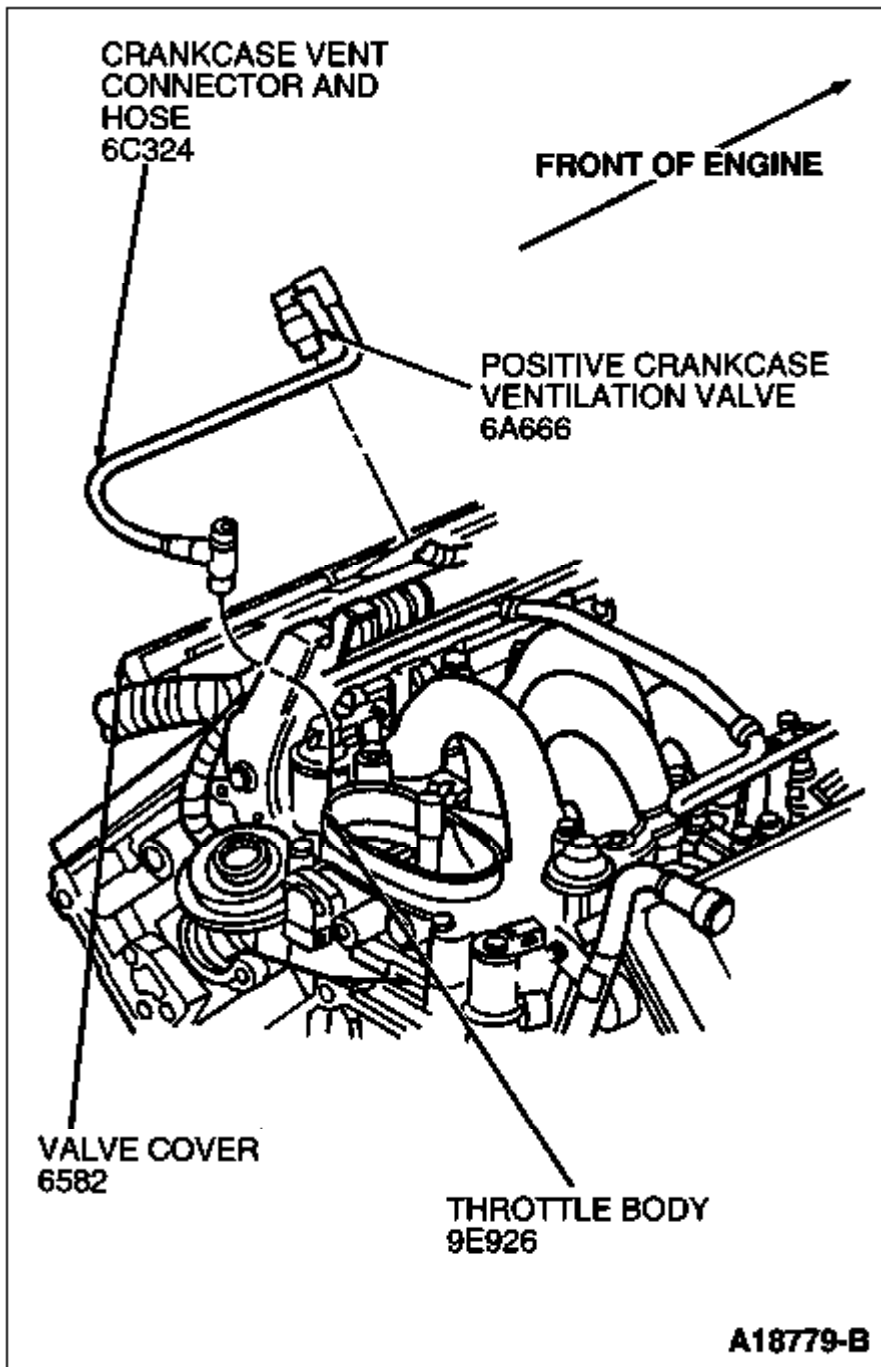

28. Remove lifting eyes from LH and RH cylinder heads.
29. Disconnect engine control sensor wiring from camshaft position sensor, oil pressure sender (9278), crankshaft position sensor, both ignition coils and both radio ignition interference capacitors (18801).

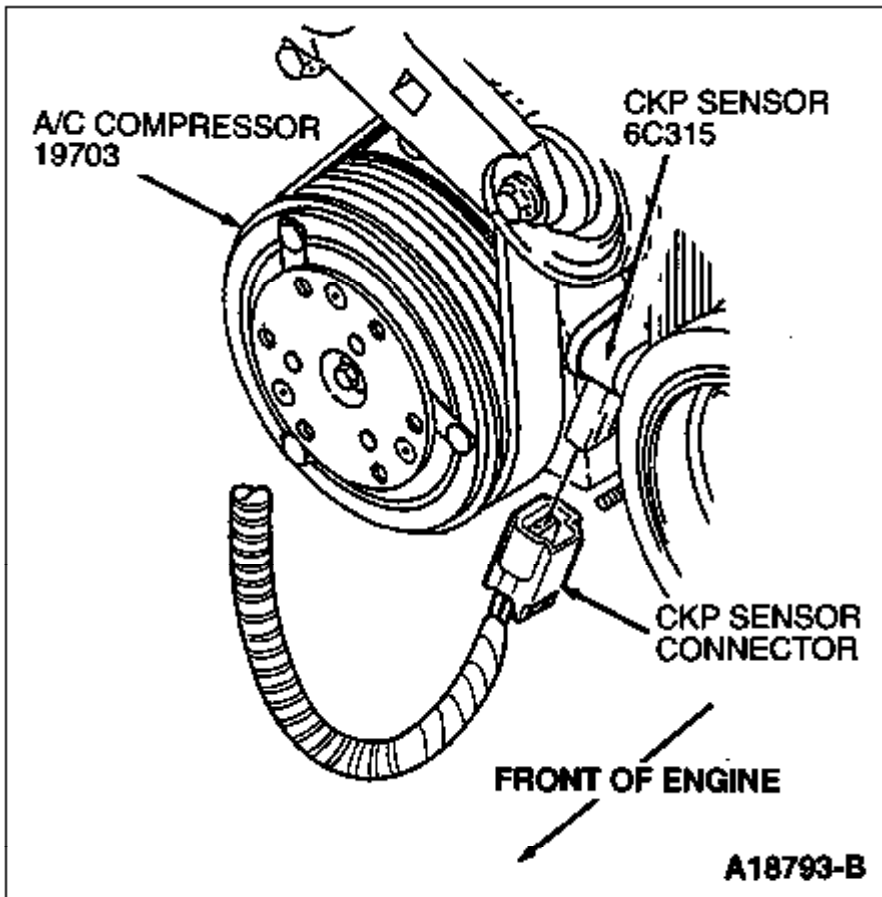

30. Disconnect engine control sensor wiring from knock sensor harness, RH heated oxygen sensor, throttle position sensor, idle air control valve, EGR vacuum regulator control and IMRC solenoids.
31. Disconnect remaining positioning clips on engine control sensor wiring.
32. Disconnect fuel injectors and remove fuel charging wiring.
33. Remove two bolts retaining accelerator cable bracket to LH cylinder head and remove accelerator cable bracket.

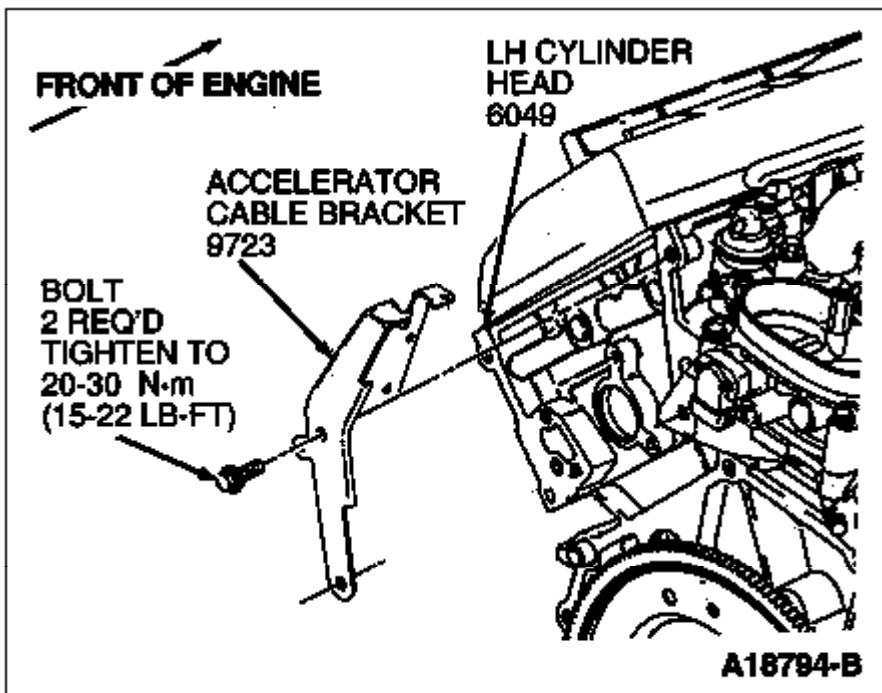

34. Remove oil level indicator tube retaining nut from valve cover and remove oil level indicator and oil

level indicator tube from cylinder block.

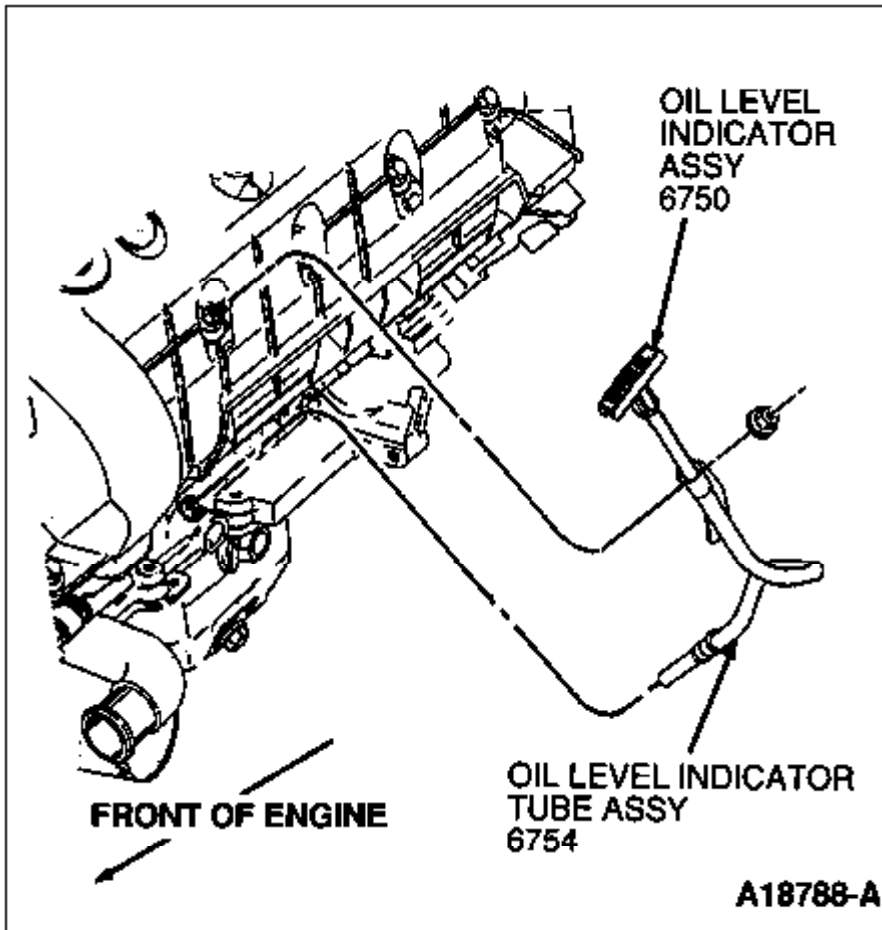

35. Remove eight RH exhaust manifold retaining bolts and remove exhaust manifold. Discard exhaust manifold gasket.
36. Loosen and remove 20 bolts and studs retaining intake manifold to cylinder heads using de-torque sequence as follows.

Intake Manifold De-Torque Sequence

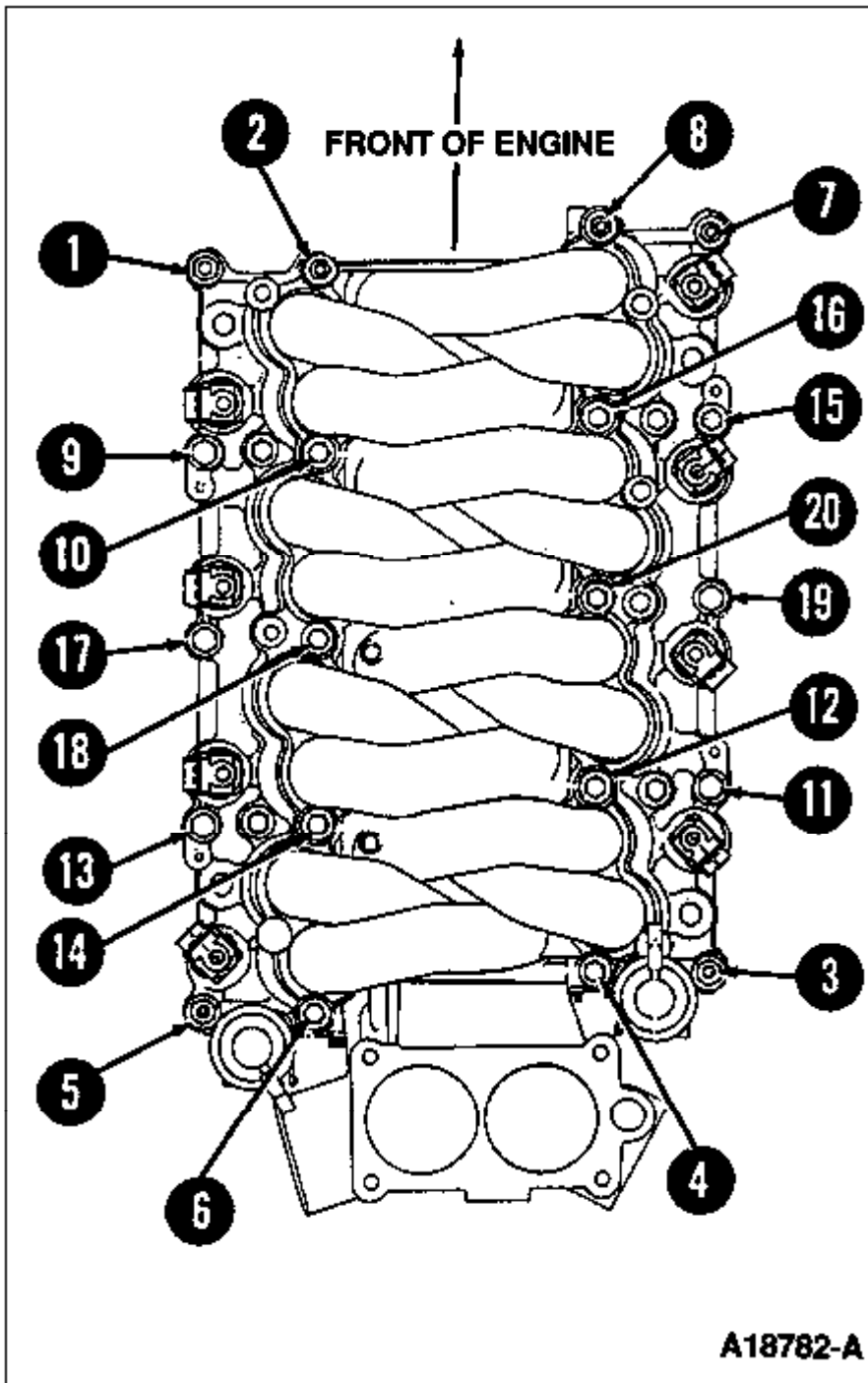

A18782-A

37. Remove intake manifold and IMRC units as an assembly.
38. Remove four fuel injection supply manifold bolts and two fuel pressure regulator bracket bolts from intake manifold and remove fuel injection supply manifold from fuel injectors.

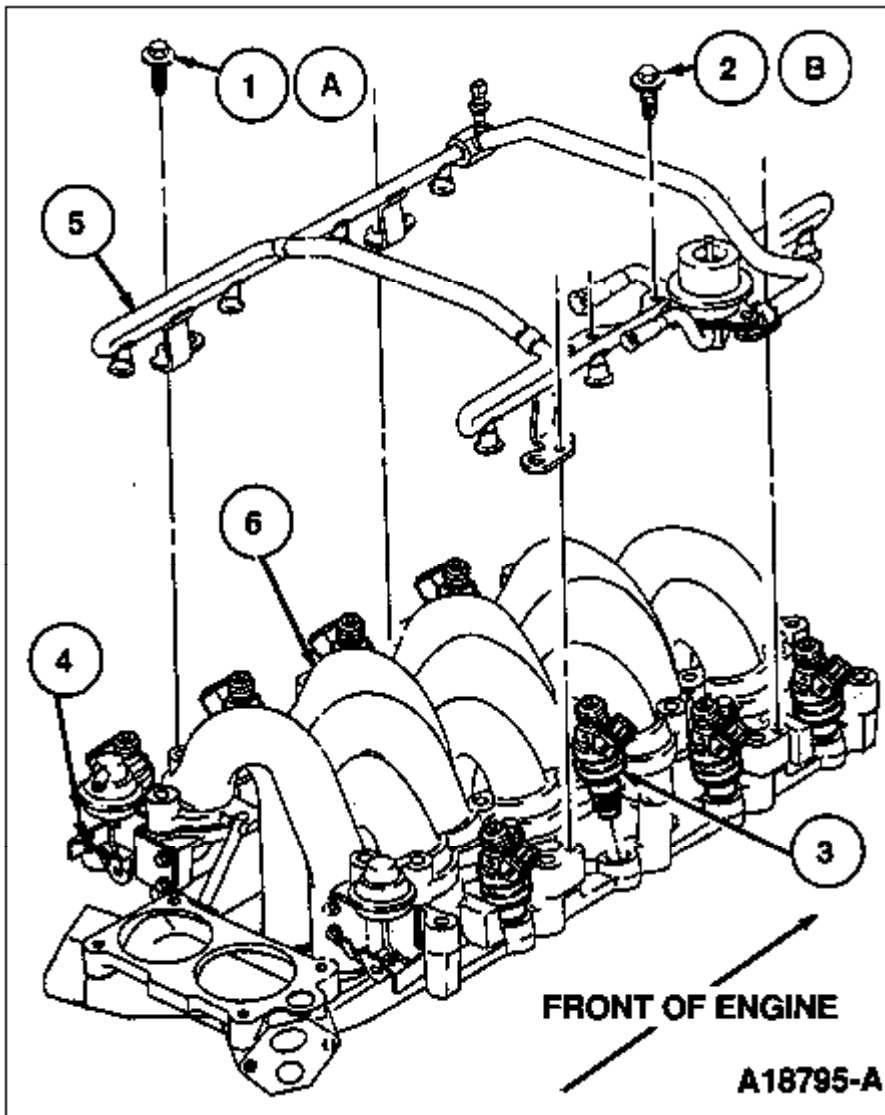

| Item | Part Number | Description |
|------|-------------|--|
| 1A | N804394-S8M | Fuel Injection Supply Manifold Retaining Bolt (4 Req'd) |
| 2B | N804394-S8M | Fuel Pressure Regulator Bracket Retaining Bolt (2 Req'd) |
| 3 | 9F593 | Fuel Injector (8 Req'd) |
| 4 | 9U531 | Intake Manifold Runner Control (IMRC) (2 Req'd) |
| 5 | 9F792 | Fuel Injection Supply Manifold |
| 6 | 9424 | Intake Manifold |
| A | | Tighten to 3-5 N-m (27-44 Lb-In) |
| B | | Tighten to 8-12 N-m (70-106 Lb-In) |

39. Remove four bolts retaining RH and LH IMRC units to intake manifold and remove IMRC units.

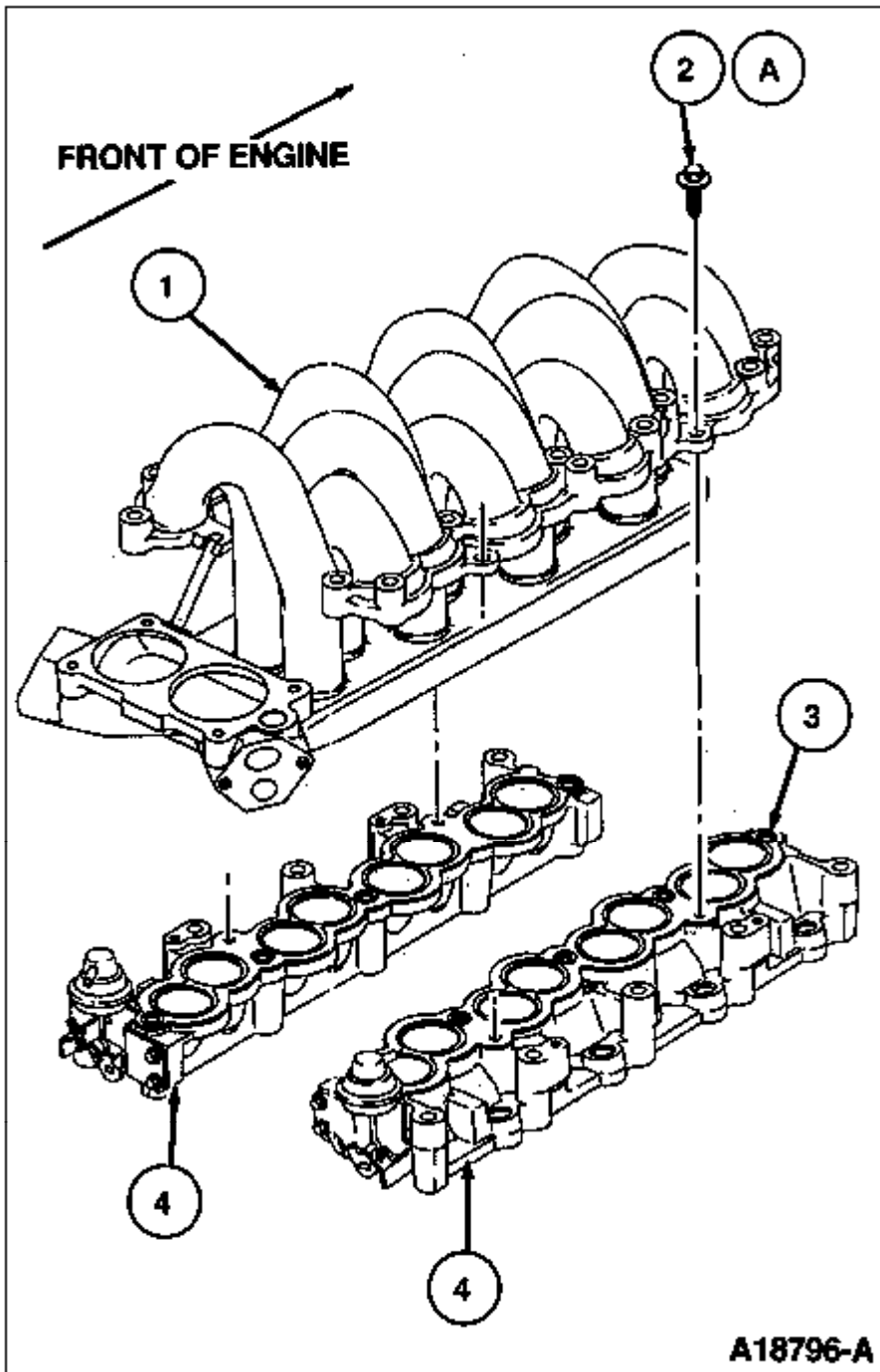

| Item | Part Number | Description |
|------|-------------|---|
| 1 | 9424 | Intake Manifold |
| 2A | N806156-S2 | Intake Manifold-To-IMRC Retaining Bolt (4 Req'd) |
| 3 | 9H486 | Intake Manifold Upper Gasket |
| 4 | 9U531 | IMRC (2 Req'd) |
| A | | Tighten to 8-10 N-m (70-89 Lb-In) |

NOTE:

Intake manifold upper gaskets must be replaced when intake manifold retaining bolts have been loosened.

40. Remove intake manifold upper gasket and all load limiting spacers from RH and LH IMRC units and discard.
41. Remove intake manifold gaskets from cylinder heads and discard.
42. Remove three bolts retaining RH coil bracket to engine front cover and remove ignition coil and bracket.
43. Remove three nuts and one bolt retaining LH coil bracket to engine front cover and remove ignition coil and bracket.
44. Remove four bolts retaining water pump to cylinder block and remove water pump.
45. Remove bolt retaining belt idler pulley to engine front cover and slide belt idler pulley from engine front cover.
46. Remove crankshaft pulley retaining bolt and washer from crankshaft.
47. Install Crankshaft Damper Remover T58P-6316-D on crankshaft pulley and remove crankshaft pulley.

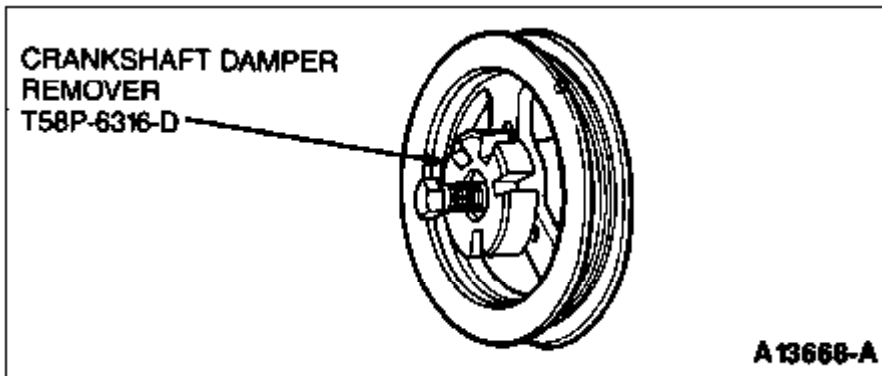

48. Remove bolts and stud bolts retaining RH valve cover to cylinder head and remove RH valve cover.
49. Remove bolts and stud bolts retaining LH valve cover to cylinder head and remove LH valve cover.

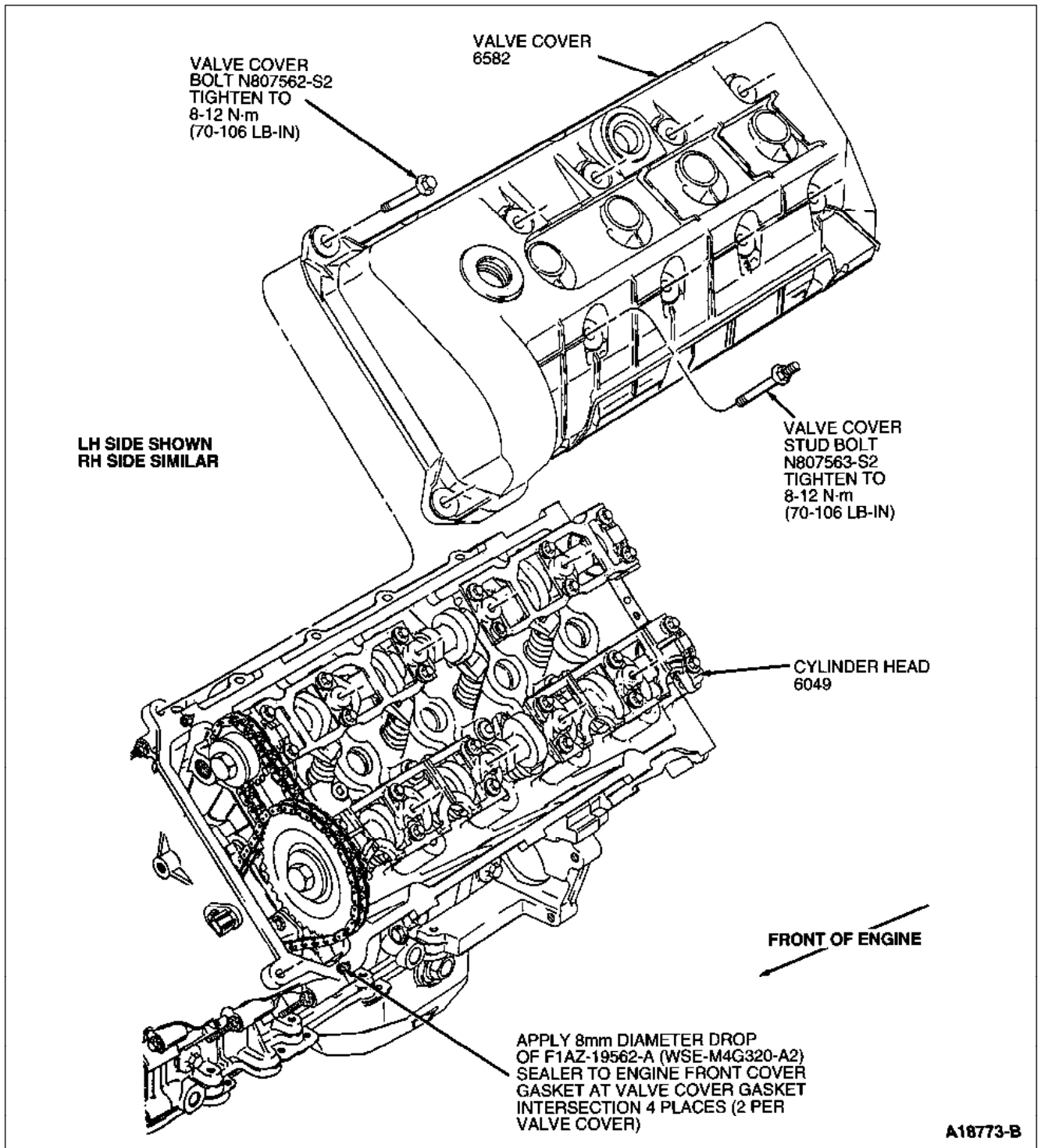

50. Remove eight spark plugs.
51. Remove four bolts retaining oil pan to engine front cover.
52. Remove seven stud bolts and eight bolts retaining engine front cover to engine.

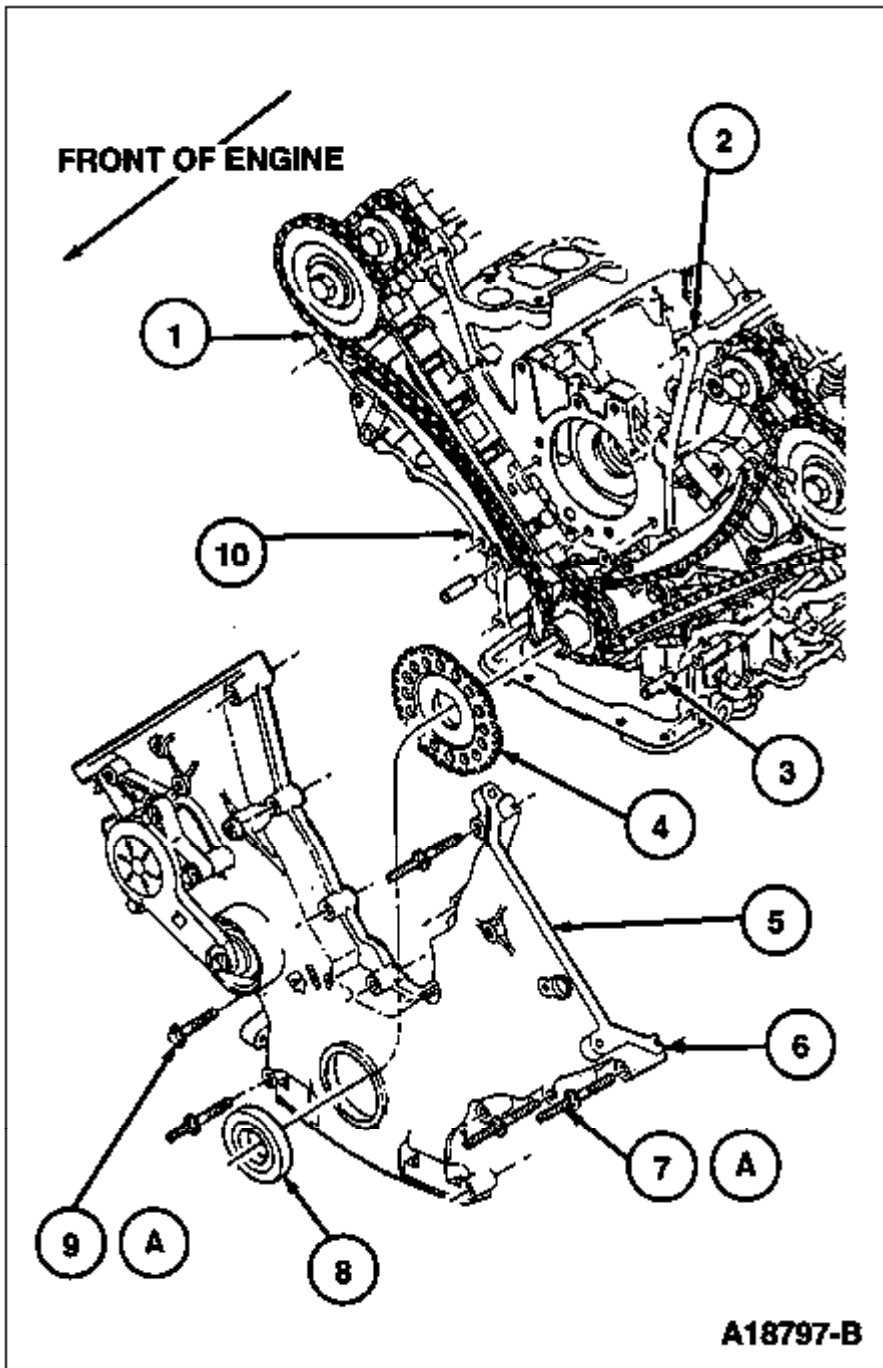

| Item | Part Number | Description |
|------|-------------|--|
| 1 | 6049 | RH Cylinder Head |
| 2 | 6049 | LH Cylinder Head |
| 3 | N806040-S | Dowel Pin |
| 4 | 12A227 | Ignition Pulse, Crankshaft Sensor Ring |
| 5 | 6020 | Engine Timing Cover Gasket |
| 6 | 6019 | Engine Front Cover |
| 7A | N806300-S2 | Hex Head Stud |
| 8 | 6700 | Crankshaft Front Seal |

| | | |
|----|------------|------------------------------------|
| 9A | N806177-S2 | Hex Flange Bolt |
| 10 | 6010 | Cylinder Block |
| A | | Tighten to 20-30 N-m (15-22 Lb-Ft) |

53. Remove harness from both knock sensors and remove wiring retainer clip from heater outlet hose assembly. Remove harness.
54. Remove two stud bolts retaining heater hose brackets at rear of RH cylinder head.
55. Release heater hose outlet connection clamp at water bypass tube connector on cylinder block and remove heater outlet tube.

NOTE:

Cylinder heads must not be set on head face with rocker arms installed. After rocker arms are removed, protect head face surface to avoid scratches and dents on cylinder head face sealing surfaces.

56. Remove rocker arms from intake valves and exhaust valves on cylinder heads as outlined in «Cylinder Head» , Disassembly and Assembly procedures.
57. Remove timing chains as outlined.
58. Rotate crankshaft counterclockwise 45 degrees before TDC. This will position all pistons below top of block deck face.
59. Using de-torque sequence, loosen and remove ten cylinder heads to cylinder block retaining bolts on cylinder head to be removed. Repeat process on opposite side if both cylinder heads are to be removed. Remove cylinder heads.

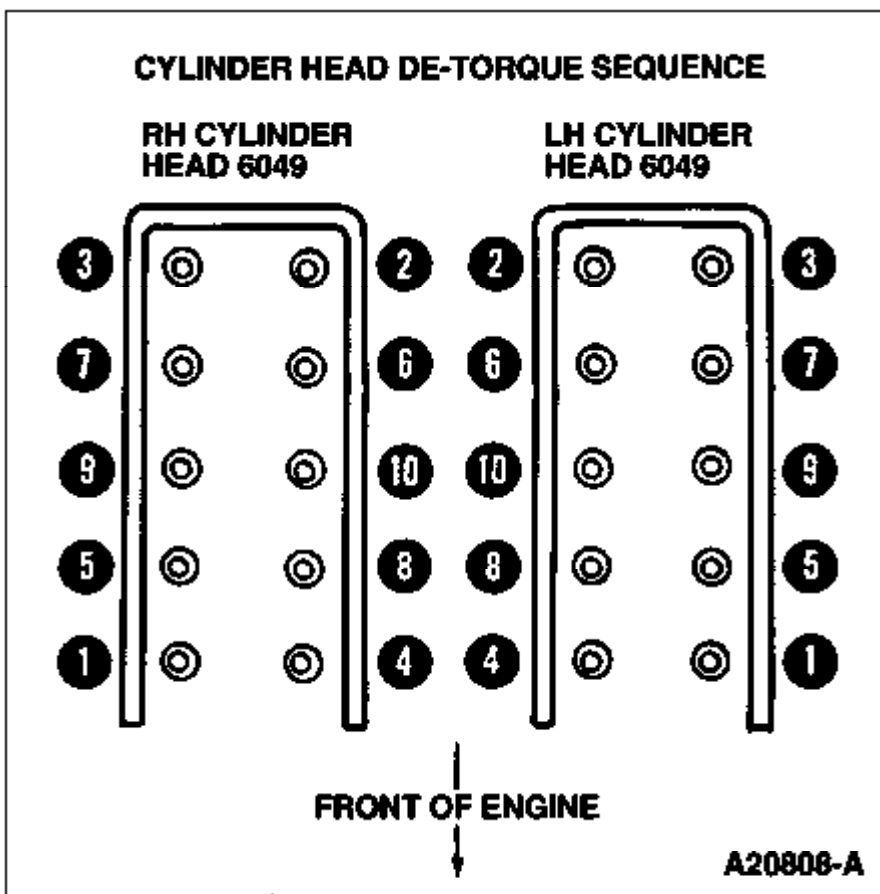

60. Discard all cylinder head bolts removed.
61. Remove head gasket and discard.

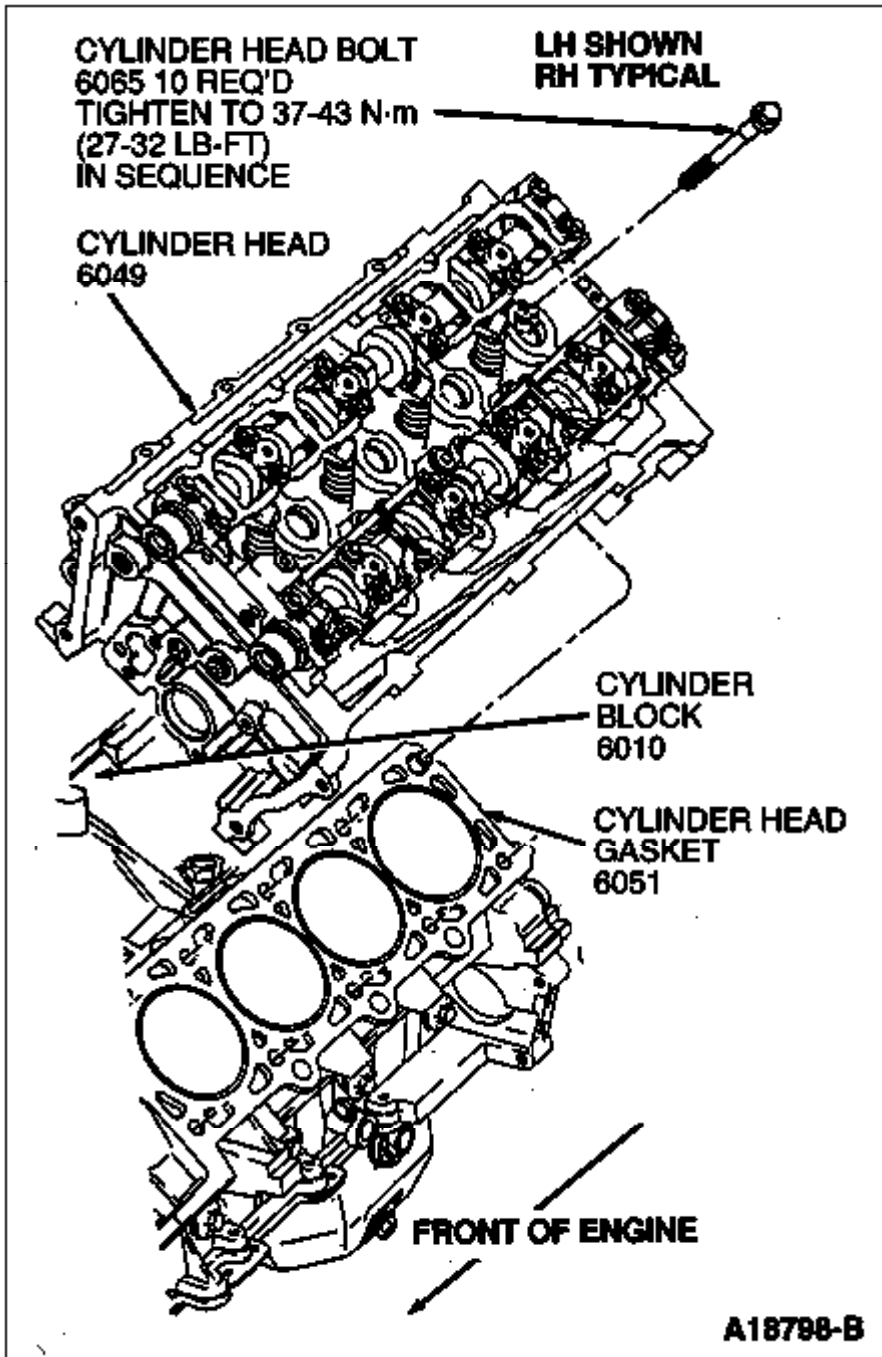

62. If cylinder head is to be replaced and/or serviced, refer to [«Cylinder Head»](#) Disassembly and Assembly as outlined.
63. Remove 12 oil pan retaining bolts. Remove oil pan and oil pan gasket.

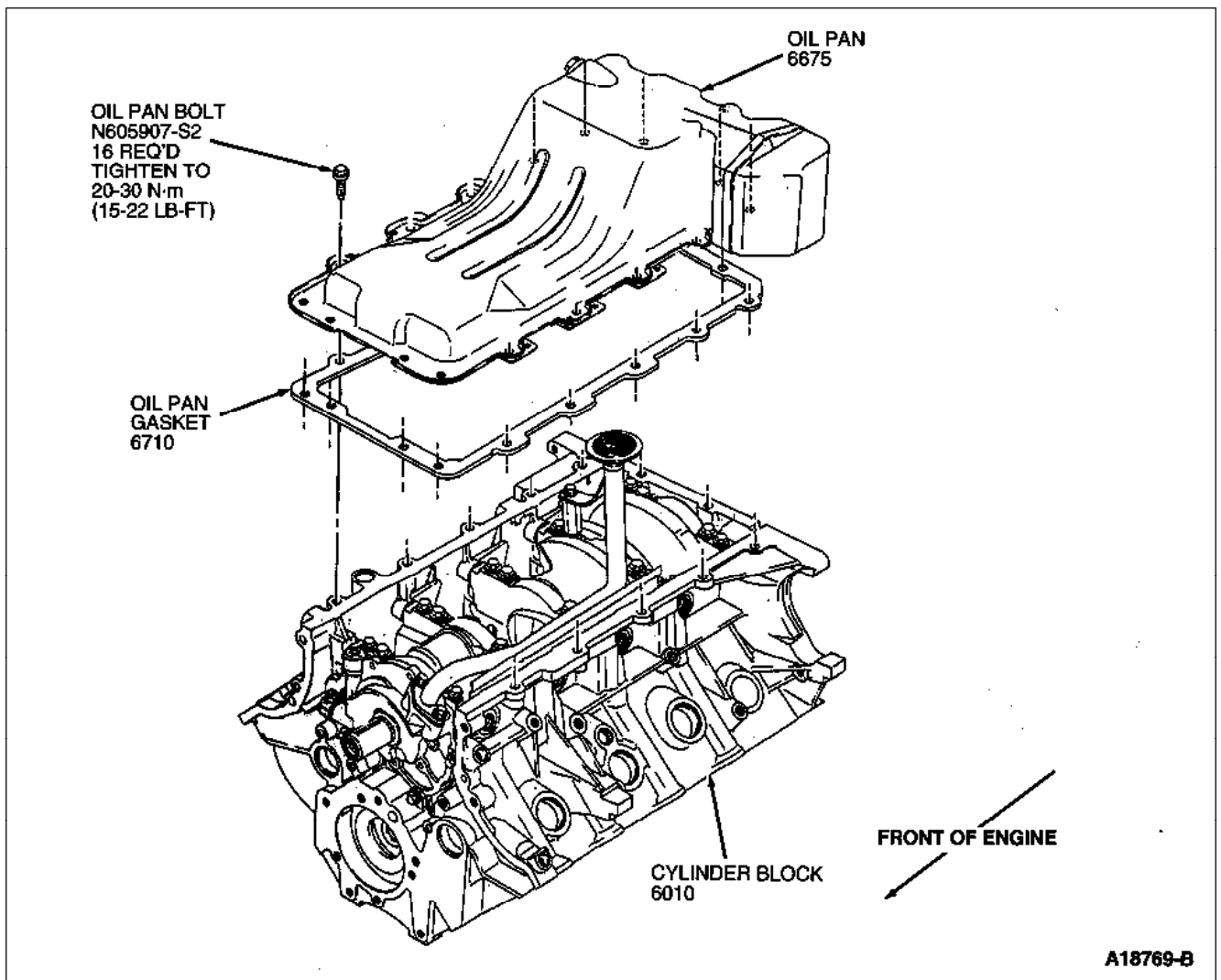

64. Remove three oil pump screen cover and tube retaining bolts. Remove oil pump screen cover and tube and O-ring.
65. Remove oil pump screen cover and tube spacer from main bearing cap stud.
66. Remove four oil pump retaining bolts and remove oil pump
67. Remove oil bypass filter. If needed, remove oil pressure sender prior to oil filter adapter removal.
68. Remove four bolts retaining oil filter adapter to cylinder block. Remove oil filter adapter and oil filter adapter gasket (6840).

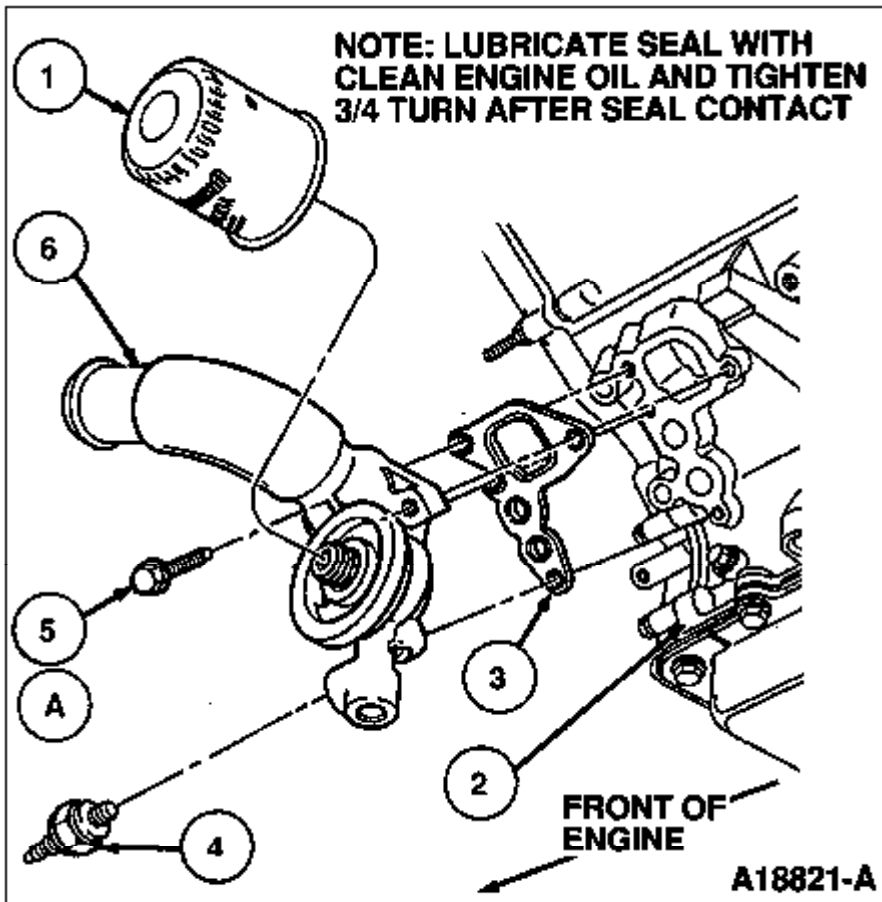

| Item | Part Number | Description |
|------|-------------|------------------------------------|
| 1 | 6714 | Oil Bypass Filter |
| 2 | 6010 | Cylinder Block |
| 3 | 6840 | Oil Filter Adapter Gasket |
| 4 | 9278 | Oil Pressure Sender |
| 5A | N806156-S2 | Bolt (4 Req'd) |
| 6 | 6881 | Oil Filter Adapter |
| A | | Tighten to 20-30 N-m (15-22 Lb-Ft) |

NOTE:

Pistons, connecting rods and connecting rod bearings should be numbered to ensure they are assembled in their original positions.

NOTE:

Before removing pistons, inspect the top of the cylinder bores. If necessary, remove the ridge and/or carbon deposits from each cylinder using Cylinder Ridge Reamer T64L-6011-EA following manufacturer's instructions.

69. Turn crankshaft until piston to be removed is at the high point of its travel.
70. If more than one piston is being removed, identify the pistons, connecting rods and connecting rod caps for cylinder position.
71. Remove the connecting rod cap and lower connecting rod bearing. Keep cap and lower

connecting rod bearing together. Using Piston and Rod Guide Tool T93P-6136-A inserted into the bottom of connecting rod bolt holes, push the piston, connecting rod and upper connecting rod bearing through the top of the cylinder bore. Use care to prevent damage to the crankshaft bearing and cylinder bore surfaces. Keep upper bearing and connecting rod together.

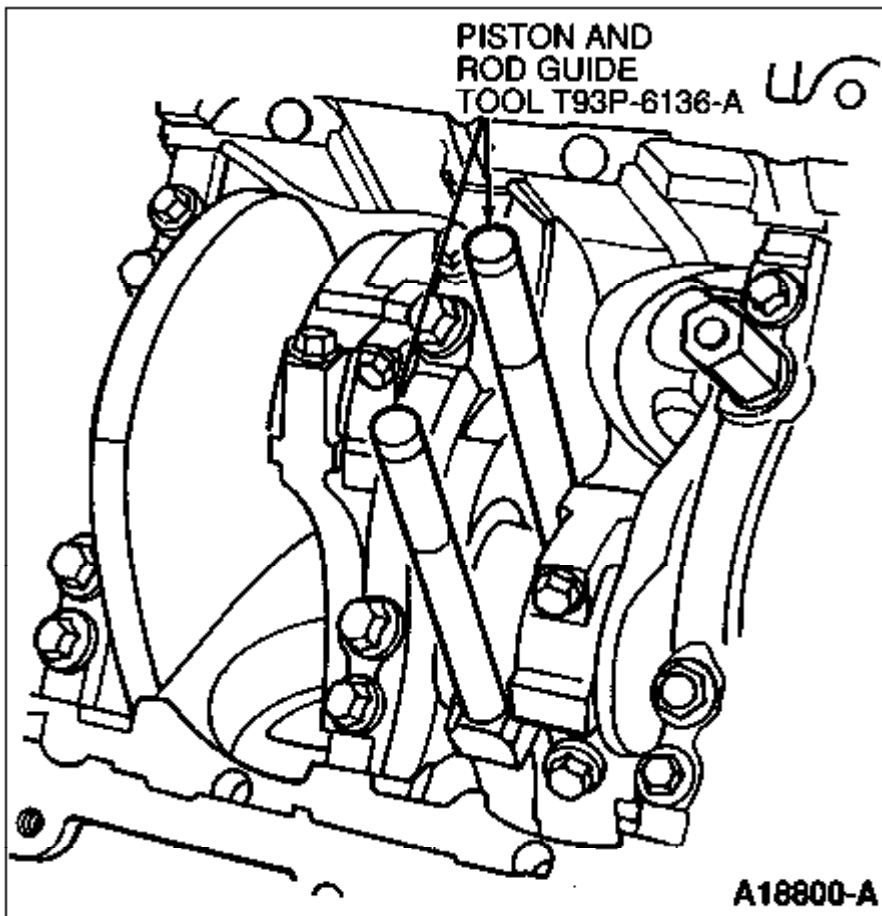

NOTE:

Connecting rod bolts (6214) are retained in the bolt hole with a light press fit. The connecting rod bolts have been torqued to yield at least twice and must be discarded. Use a hammer and punch to drive connecting rod bolt from bolt hole.

CAUTION:

Care should be taken not to damage the fractured rod and cap joint face surfaces.

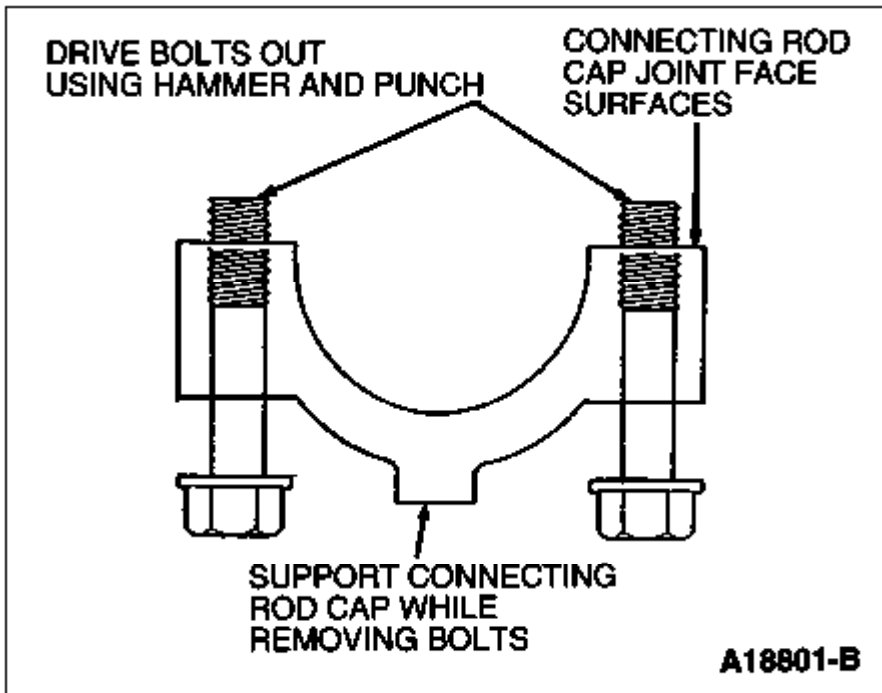

72. Using new connecting rod bolts, attach cap and lower connecting rod bearing to connecting rod and upper connecting rod bearing (finger-tight) to prevent mixing parts and damaging the fractured joint face surfaces.

NOTE:

Any piston rings that are removed from piston should be discarded and replaced with new rings.

73. If piston ring replacement is required, use a suitable piston ring expander to remove two compression rings. Remove two oil ring rails and expander by hand.

WARNING:

COVER THE END OF THE PIN BORE WITH A HAND OR SHOP RAG WHEN REMOVING THE RETAINER RING SINCE IT HAS A TENDENCY TO SPRING OUT. EYE PROTECTION SHOULD BE WORN.

74. Using O-Ring Remover Tool T71P-19703-C, remove the two piston pin retaining rings.

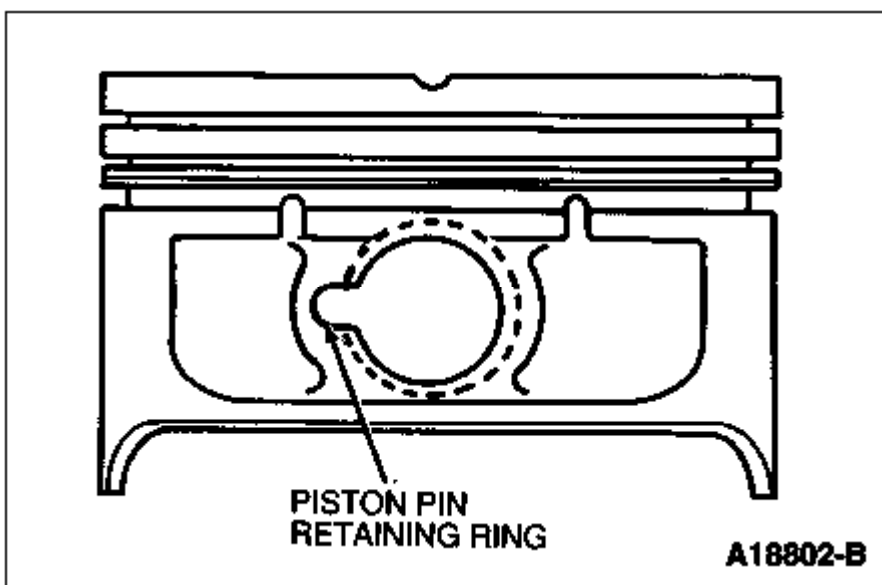

75. Gradually heat the piston to approximately 100°C (212°F).

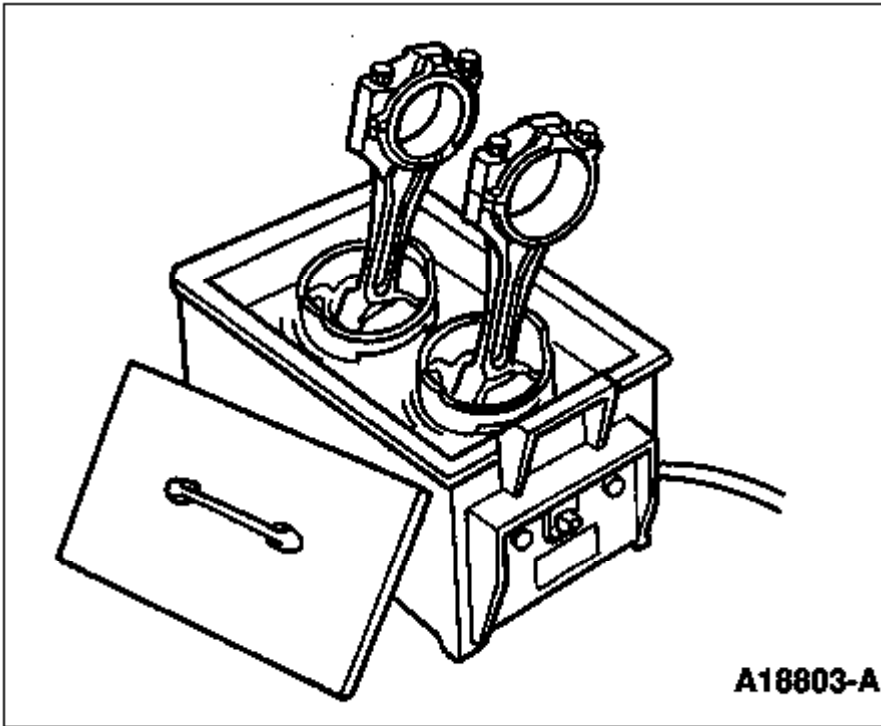

NOTE:

The piston and piston pin (6135) are a matched set. Keep pistons, piston pins, rings, connecting rods and connecting rod bearings together in proper cylinder order.

76. Using Piston Pin Remover D81L-6135-A or equivalent, press piston pin from piston and connecting rod.

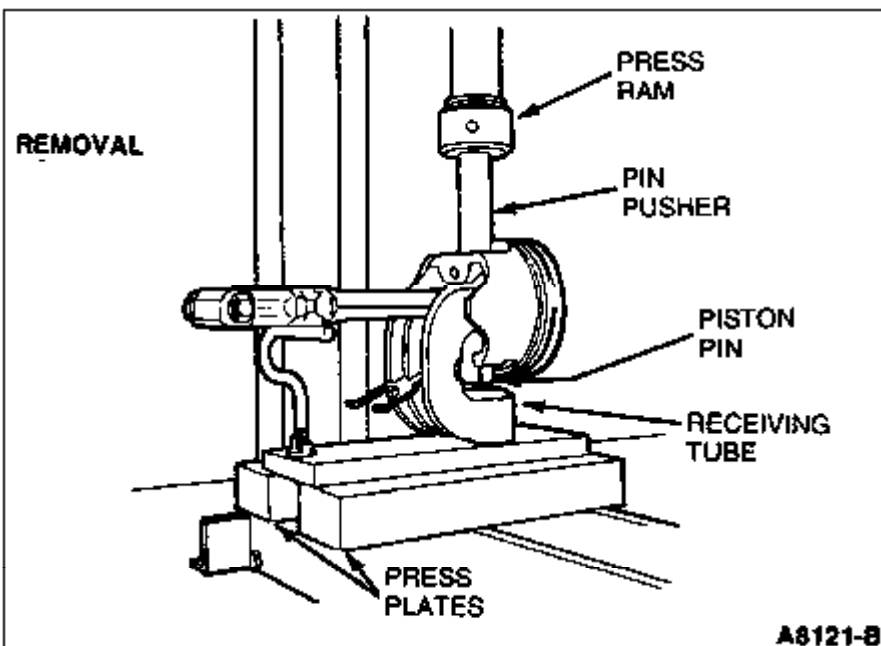

77. Remove crankshaft rear oil seal and retainer (6K301).

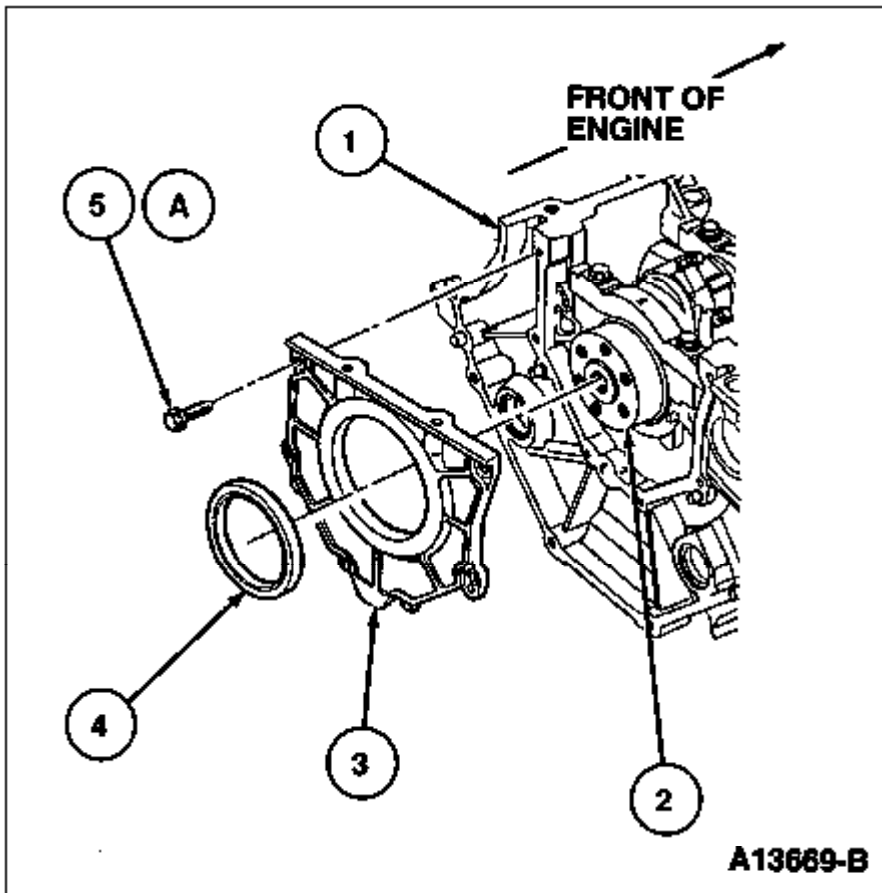

| Item | Part Number | Description |
|------|-------------|------------------------------------|
| 1 | 6010 | Cylinder Block |
| 2 | — | Crankshaft Flange (Part of 6303) |
| 3 | 6335 | Crankshaft Rear Oil Seal Retainer |
| 4 | 6701 | Crankshaft Rear Oil Seal |
| 5A | — | Screw and Washer Assy (6 Req'd) |
| A | | Tighten to 8-12 N-m (70-106 Lb-In) |

NOTE:

The location of the main bearing caps and the crankshaft main bearings should be identified. When the engine is assembled, crankshaft main bearings which are to be reused should be installed in their original positions.

78. Remove ten horizontal main cap side bolts from cylinder block to main bearing caps using de-torque sequence as follows. Save bolts for reinstallation.

De-Torque Sequence

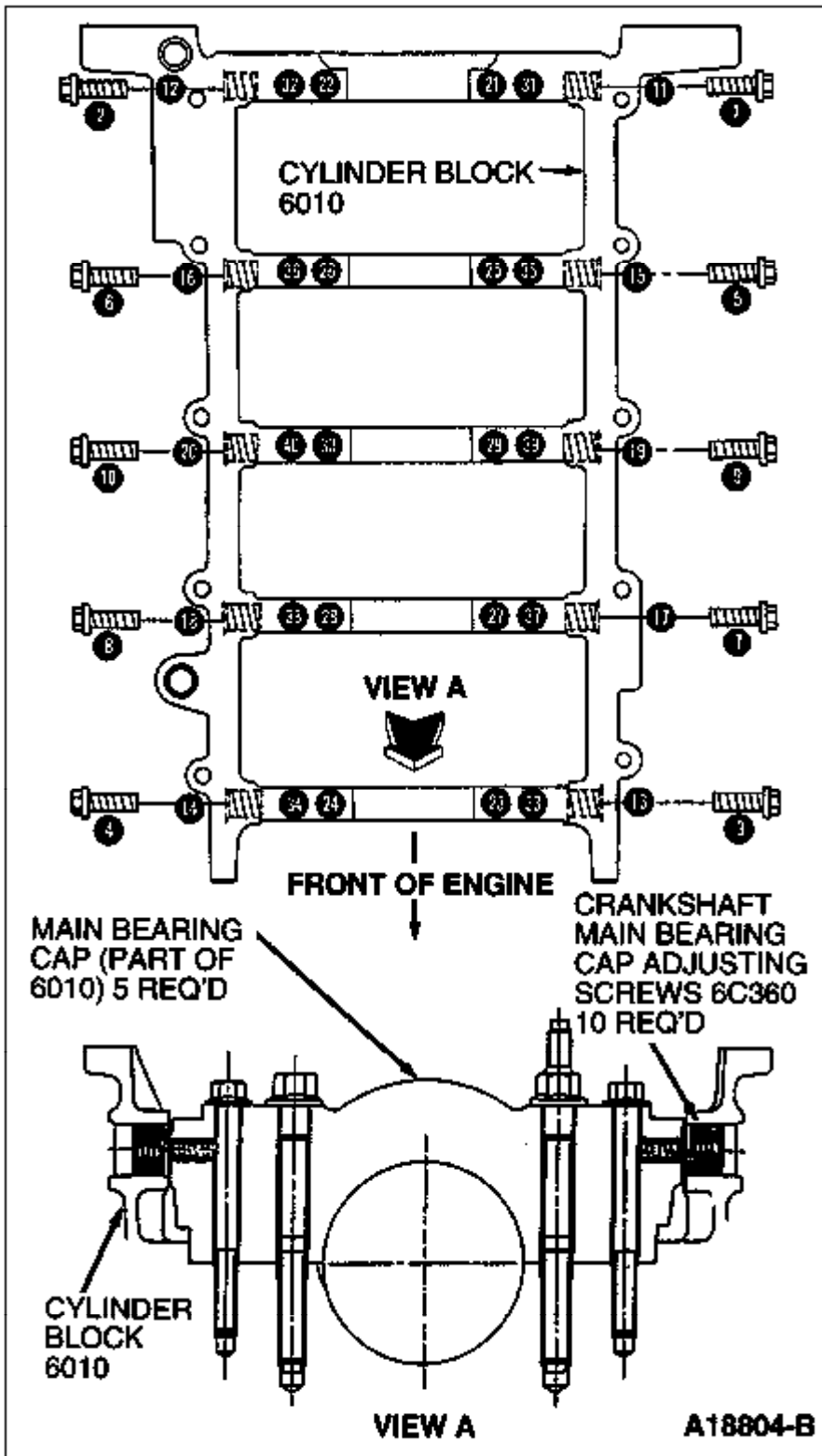

79. With a 3/8 inch hex socket, loosen crankshaft main bearing cap adjusting screw (6C360) in a de-torque sequence as shown.
80. Loosen and remove 20 vertical bearing main cap retaining bolts in a de-torque sequence as shown and discard vertical bolts. These are torque-to-yield bolts and should not be reused.
81. Remove each main bearing cap and lower crankshaft main bearing. Keep each cap and lower crankshaft main bearing together.

CAUTION:

When removing the crankshaft, use care not to damage any of the bearing surfaces on the crankshaft.

82. Remove crankshaft.
83. Remove No. 5 upper thrust bearing washer from rear of No. 5 upper main bulk head.
84. Remove and mark position of five upper crankshaft main bearings.

NOTE:

Before assembling cylinder block, all sealing surfaces must be clean and free of chips, dirt, paint and foreign material. Use only plastic-tipped scraper on any stubborn debris. Also, make sure coolant and oil passages are clear.

Select-Fit Bearings

The 4.6L-4V modular engine uses a three grade select-fit bearing system. There are two seven-character strings on the cylinder block and crankshaft, along with the select fit main bearing grade chart. The first five characters in the string represent the bore/journal sizes. The last two characters are used as a check-sum and may be neglected.

The procedure for selectively fitting the crankshaft main bearings is as follows:

1. Read the first character (from left to right) on the cylinder block and make a note of it. The character will be a letter between A and X. The character string is located on the front face of the cylinder block.
2. Read the first character on the edge of the No. 7 counterweight on the crankshaft and make a note of it. The character will be a letter between A and X.

Code Locations

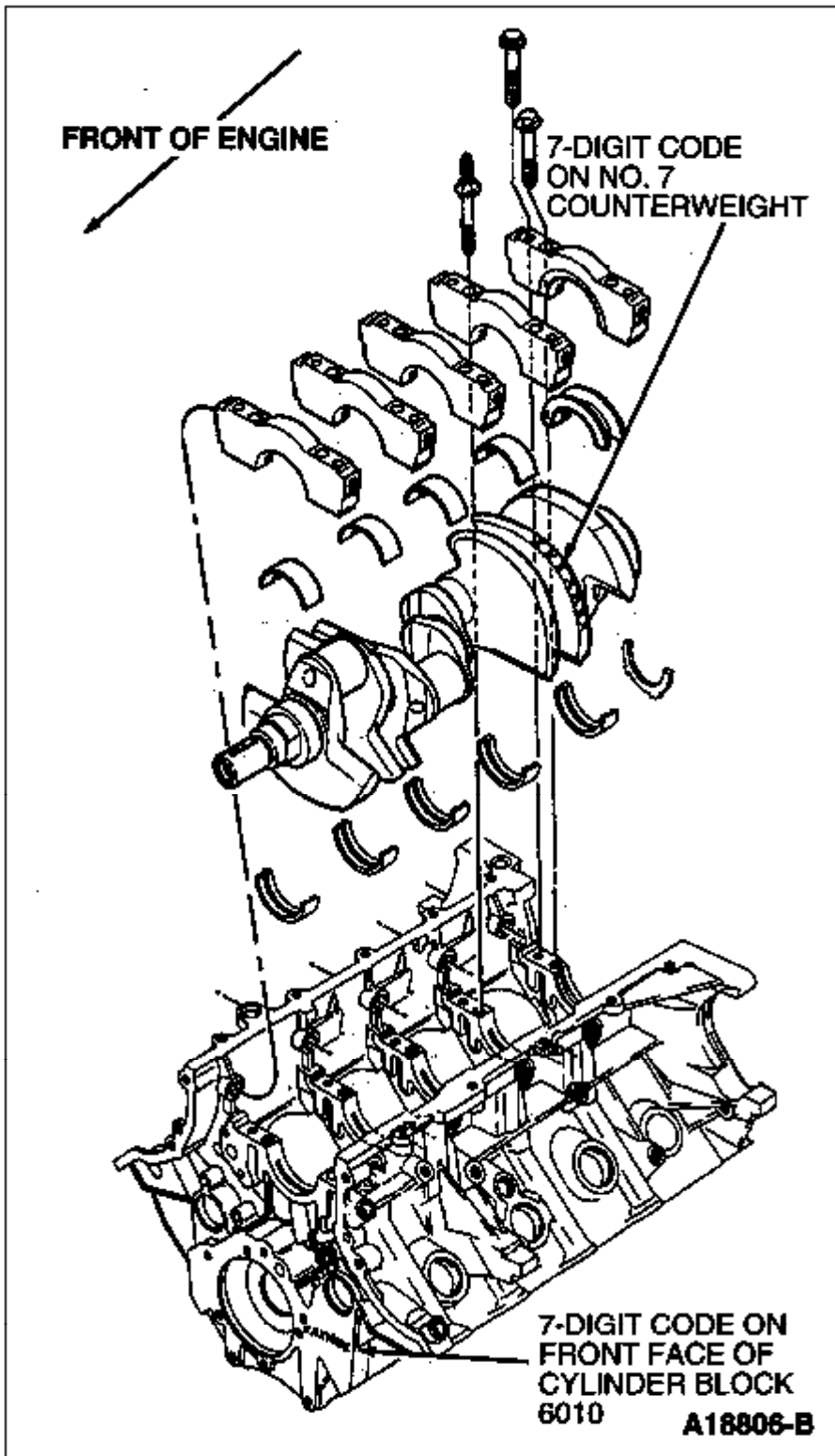

- Using the Select Fit Main Bearing Grade Chart and the two characters (A-X) noted above, move across and down the appropriate row and column to select the bearing grade for the No. 1 main journal.

4.6L 4V 24x24x3 SELECT FIT MAIN BEARING GRADE CHART

| | | M I N I M U M B L O C K D I A | | | | | | | | | | | | | | | | | | | | | | | |
|---|--------|-------------------------------|------|------|------|------|------|------|------|------|------|------|------|------|------|------|------|------|------|------|------|------|------|------|------|
| | | A | B | C | D | E | F | G | H | I | J | K | L | M | N | O | P | Q | R | S | T | U | V | W | X |
| | | .401 | .402 | .403 | .404 | .405 | .406 | .407 | .408 | .409 | .410 | .411 | .412 | .413 | .414 | .415 | .416 | .417 | .418 | .419 | .420 | .421 | .422 | .423 | .424 |
| X | 67.504 | 1 | 1 | 1 | 1 | 1 | 1 | 1 | 1 | 1 | 1 | 1 | 1 | 1 | 1 | 1 | 1 | 1 | 2 | 2 | 2 | 2 | 2 | 2 | 2 |
| W | 67.503 | 1 | 1 | 1 | 1 | 1 | 1 | 1 | 1 | 1 | 1 | 1 | 1 | 1 | 1 | 1 | 1 | 2 | 2 | 2 | 2 | 2 | 2 | 2 | 2 |
| M | V | 67.502 | 1 | 1 | | | | | | | 1 | 1 | 1 | 1 | 1 | 1 | 2 | 2 | 2 | 2 | 2 | 2 | 2 | 2 | 2 |
| A | U | 67.501 | 1 | 1 | | O | R | A | N | G | E | 1 | 1 | 1 | 1 | 1 | 2 | 2 | 2 | 2 | 2 | 2 | 2 | 2 | 2 |
| X | T | 67.500 | 1 | 1 | | | | | | | 1 | 1 | 1 | 1 | 1 | 2 | 2 | 2 | 2 | 2 | 2 | 2 | 2 | 2 | 2 |
| I | S | 67.499 | 1 | 1 | 1 | 1 | 1 | 1 | 1 | 1 | 1 | 1 | 1 | 2 | 2 | 2 | 2 | 2 | 2 | 2 | 2 | 2 | 2 | 2 | 2 |
| M | R | 67.498 | 1 | 1 | 1 | 1 | 1 | 1 | 1 | 1 | 1 | 1 | 2 | 2 | 2 | 2 | 2 | 2 | 2 | 2 | 2 | 2 | 2 | 2 | 2 |
| U | Q | 67.497 | 1 | 1 | 1 | 1 | 1 | 1 | 1 | 1 | 1 | 2 | 2 | 2 | 2 | 2 | 2 | 2 | 2 | 2 | 2 | 2 | 2 | 2 | 3 |
| M | P | 67.496 | 1 | 1 | 1 | 1 | 1 | 1 | 1 | 1 | 2 | 2 | 2 | 2 | 2 | 2 | 2 | 2 | 2 | 2 | 2 | 2 | 2 | 3 | 3 |
| O | | 67.495 | 1 | 1 | 1 | 1 | 1 | 1 | 1 | 2 | 2 | 2 | 2 | 2 | 2 | 2 | 2 | 2 | 2 | 2 | 2 | 2 | 3 | 3 | 3 |
| C | N | 67.494 | 1 | 1 | 1 | 1 | 1 | 1 | 2 | 2 | 2 | 2 | 2 | 2 | 2 | 2 | 2 | 2 | 2 | 2 | 2 | 3 | 3 | 3 | 3 |
| R | M | 67.493 | 1 | 1 | 1 | 1 | 1 | 2 | | | | | | | | | 2 | 2 | 2 | 2 | 3 | 3 | 3 | 3 | 3 |
| A | L | 67.492 | 1 | 1 | 1 | 1 | 2 | 2 | | | | | | | | | 2 | 2 | 2 | 3 | 3 | 3 | 3 | 3 | 3 |
| N | K | 67.491 | 1 | 1 | 1 | 2 | 2 | 2 | | | B | L | U | E | | | 2 | 2 | 3 | 3 | 3 | 3 | 3 | 3 | 3 |
| K | J | 67.490 | 1 | 1 | 2 | 2 | 2 | 2 | | | | | | | | | 2 | 3 | 3 | 3 | 3 | 3 | 3 | 3 | 3 |
| S | I | 67.489 | 1 | 2 | 2 | 2 | 2 | 2 | | | | | | | | | 3 | 3 | 3 | 3 | 3 | 3 | 3 | 3 | 3 |
| H | H | 67.488 | 1 | 2 | 2 | 2 | 2 | 2 | 2 | 2 | 2 | 2 | 2 | 2 | 2 | 3 | 3 | 3 | 3 | 3 | 3 | 3 | 3 | 3 | 3 |
| A | G | 67.487 | 2 | 2 | 2 | 2 | 2 | 2 | 2 | 2 | 2 | 2 | 2 | 3 | 3 | 3 | 3 | 3 | 3 | 3 | 3 | 3 | 3 | 3 | 3 |
| F | F | 67.486 | 2 | 2 | 2 | 2 | 2 | 2 | 2 | 2 | 2 | 2 | 3 | 3 | 3 | | | | | | | | | | 3 |
| T | E | 67.485 | 2 | 2 | 2 | 2 | 2 | 2 | 2 | 2 | 2 | 3 | 3 | 3 | 3 | | | | | G | R | E | E | N | 3 |
| D | D | 67.484 | 2 | 2 | 2 | 2 | 2 | 2 | 2 | 2 | 3 | 3 | 3 | 3 | 3 | | | | | | | | | | 3 |
| D | C | 67.483 | 2 | 2 | 2 | 2 | 2 | 2 | 2 | 3 | 3 | 3 | 3 | 3 | 3 | 3 | 3 | 3 | 3 | 3 | 3 | 3 | 3 | 3 | 3 |
| I | B | 67.482 | 2 | 2 | 2 | 2 | 2 | 2 | 3 | 3 | 3 | 3 | 3 | 3 | 3 | 3 | 3 | 3 | 3 | 3 | 3 | 3 | 3 | 3 | 3 |
| A | A | 67.481 | 2 | 2 | 2 | 2 | 2 | 3 | 3 | 3 | 3 | 3 | 3 | 3 | 3 | 3 | 3 | 3 | 3 | 3 | 3 | 3 | 3 | 3 | 3 |

A18807-A

- Repeat Steps 1 through 3 for the other four main journals. (The second letter in the character string is for main journal No. 2, the third for main journal No. 3 etc.)

Assembly

NOTE:

Prior to service re-installation or replacement of fasteners, all threads and contact surfaces must be lubricated with engine oil.

- Lubricate and install five upper crankshaft main bearings into cylinder block.
- Install crankshafts.
- Push crankshafts rearward. Lubricate and install upper thrust washer by rolling the washer onto machined shelf between rear side of No. 5 bulk head and thrust surface of crankshaft. **Ensure coated side of thrust washer with three 5mm wide oil grooves faces the crankshaft thrust surface.**

NOTE:

Crankshaft main bearing cap adjusting screw must be retracted into cylinder block wall away from main bearing cap contact prior to main cap installation and vertical bolt tightening.

- Lubricate and install four lower crankshaft main bearings into bearing caps 1 through 4 and install onto cylinder block.
- Lubricate and install No. 5 crankshaft thrust main bearing into No. 5 cap and install cap onto cylinder block.

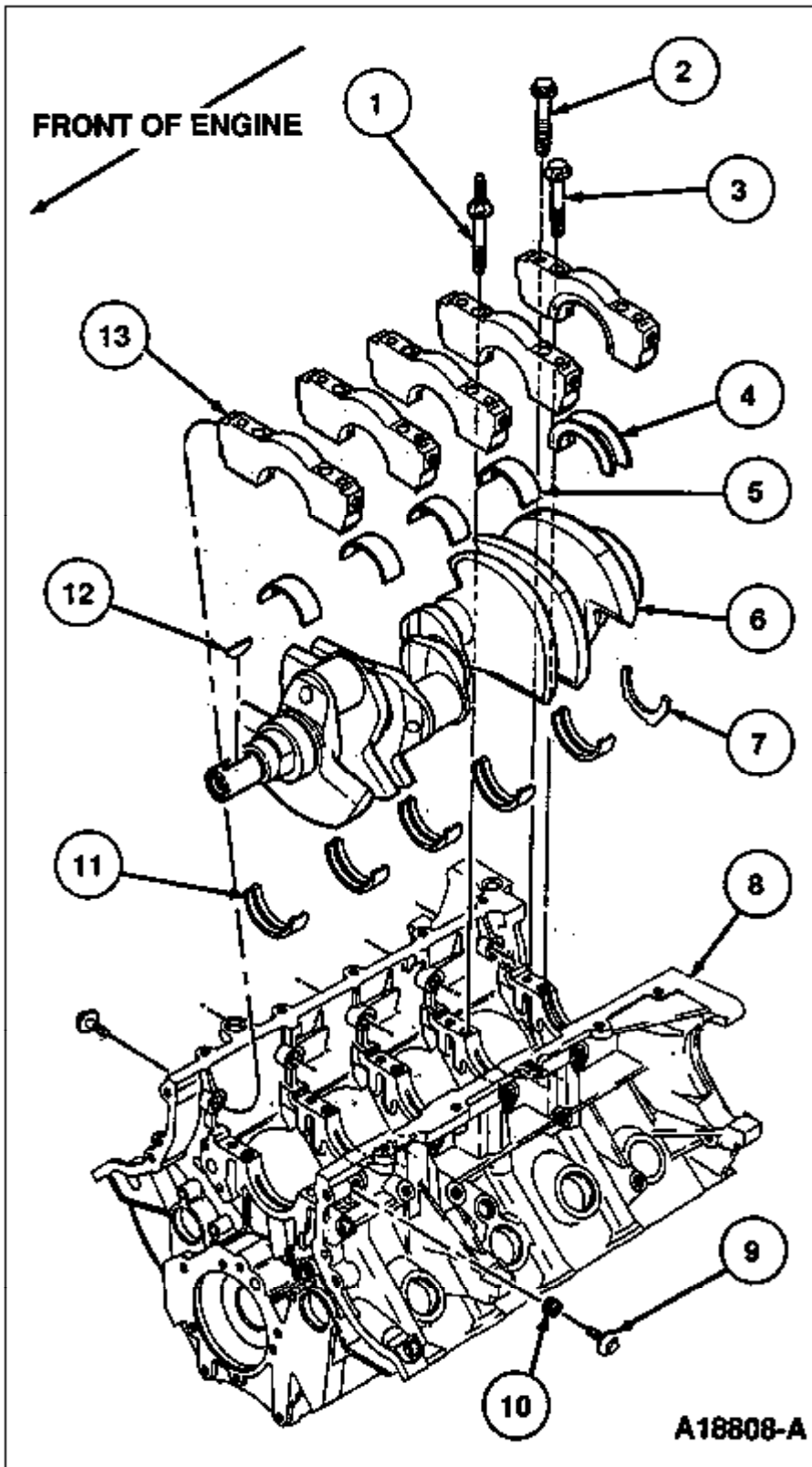

A18808-A

| Item | Part Number | Description |
|------|----------------|--|
| 1 | 6345 | Crankshaft Main Bearing Cap Stud |
| 2 | M8 X 1.25 X 80 | Hex Flange Head Pilot Bolt (10 Req'd) |
| 3 | 6345 | Crankshaft Main Bearing Cap Bolt (9 Req'd) |
| 4 | 6337 | Lower Crankshaft Thrust Main Bearing |

| | | |
|----|-------|--|
| 5 | 6333 | Lower Crankshaft Main Bearing (4 Req'd) |
| 6 | 6303 | Crankshaft |
| 7 | 6334 | Crankshaft Thrust Washer |
| 8 | 6010 | Cylinder Block |
| 9 | 6C358 | Main Cap Side Bolt (10 Req'd) |
| 10 | 6C360 | Crankshaft Main Bearing Cap Adjusting Screw (10 Req'd) |
| 11 | 6333 | Upper Crankshaft Main Bearing (5 Req'd) |
| 12 | 6B316 | Crankshaft Key |
| 13 | 6325 | Main Bearing Cap 5 Req'd) |

CAUTION:

Main bearing bolts must be replaced with new bolts. They are torque-to-yield designed and cannot be reused.

- Loosely install all vertical main cap retaining bolts and stud bolt, using new stud and bolts in bolt position 1 through 20. Tap main bearing caps with a brass hammer to seat caps properly.

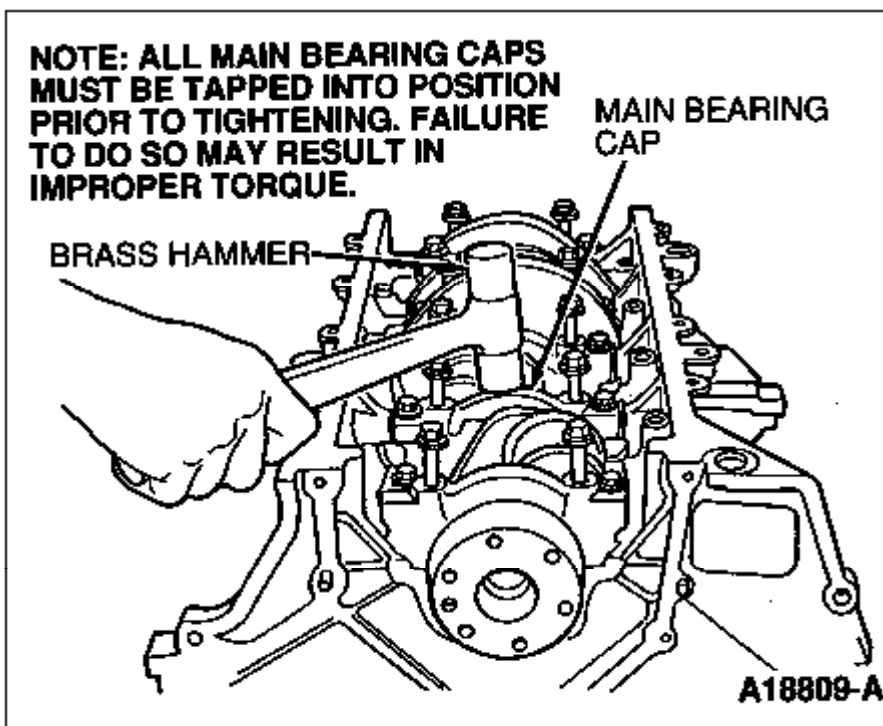

- Tighten in sequence, vertical main bolts in positions 1 through 8 to 8-12 N-m (70-106 lb-in). Then tighten vertical main bolts in positions 10 through 18 to 8-12 N-m (70-106 lb-in).

Main Bolt Torque Sequence

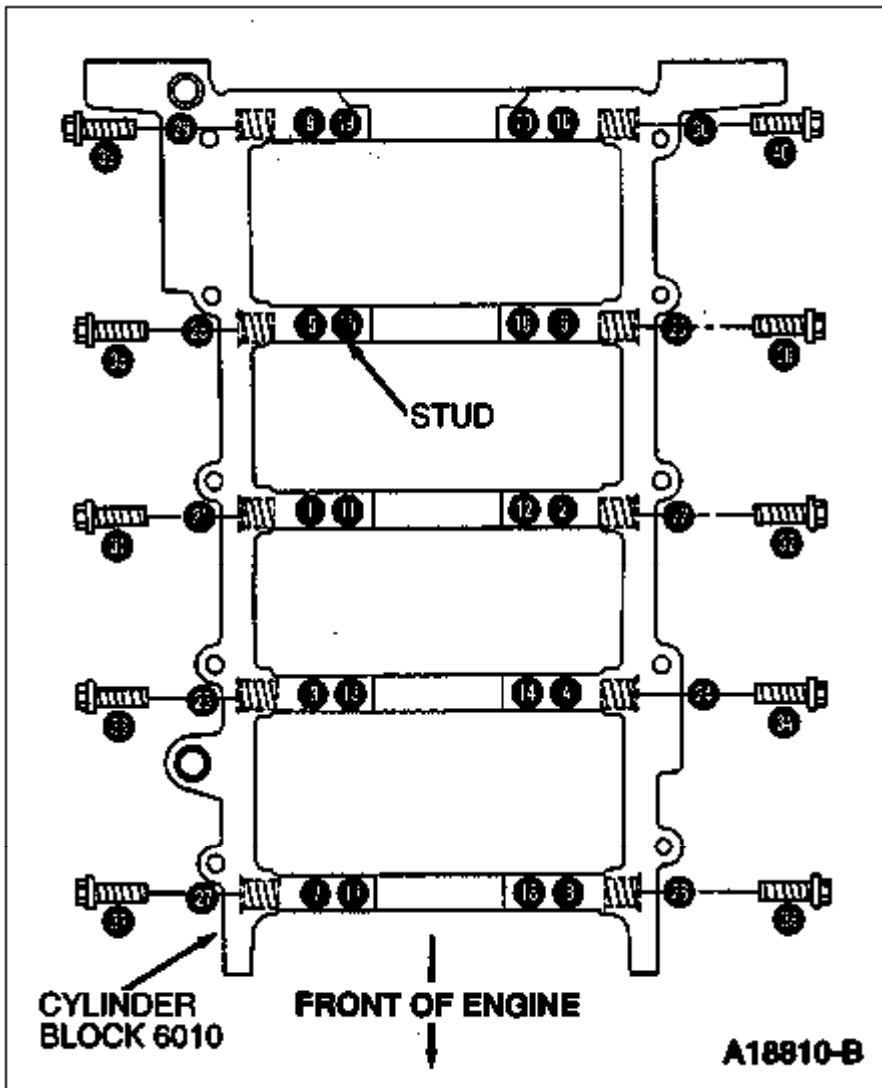

8. Push crankshaft forward and wedge using a screwdriver or similar tool to seat thrust washer.
9. With crankshafts wedged forward, use screwdrivers or similar tools to wedge both RH and LH front edges of No. 5 main bearing cap rearward to position the lower crankshaft thrust main bearing rear face properly against the thrust face of the crankshaft.

NOTE:

No. 5 main bearing cap must be seated as outlined above until the main bearing cap bolts are fully tightened as required per following procedure.

NOTE:

Wedge crankshaft in direction of arrow to fully seat thrust washer. Leave screwdrivers in position until all main bearing bolts are tightened.

10. Tighten vertical main bolts 9, 10, 19 and 20 to 8-12 N-m (70-106 lb-in) in order.
11. Tighten vertical main bolts 1 through 10 to 22-28 N-m (16-21 lb-ft).
12. Tighten vertical main bolts 11 through 20 to 37-43 N-m (27-32 lb-ft).
13. Rotate vertical main bolts 1 through 20, turning clockwise, 85-95 degrees.
14. Remove all wedges from No. 5 main cap and from crankshaft.
15. Tighten crankshaft main bearing cap adjusting screw, positions 21 through 30, in sequence to 30-55 N-m (22-25 lb-ft). Rotate 85-95 degrees clockwise.
16. Tighten main cap side bolts, positions 31 through 40, in sequence in two steps: 10 N-m (7 lb-ft), then 19-23N-m (14-17 lb-ft).

17. Check crankshaft end play in both directions as shown.

NOTE:

Pry against No. 2 main bearing cap.

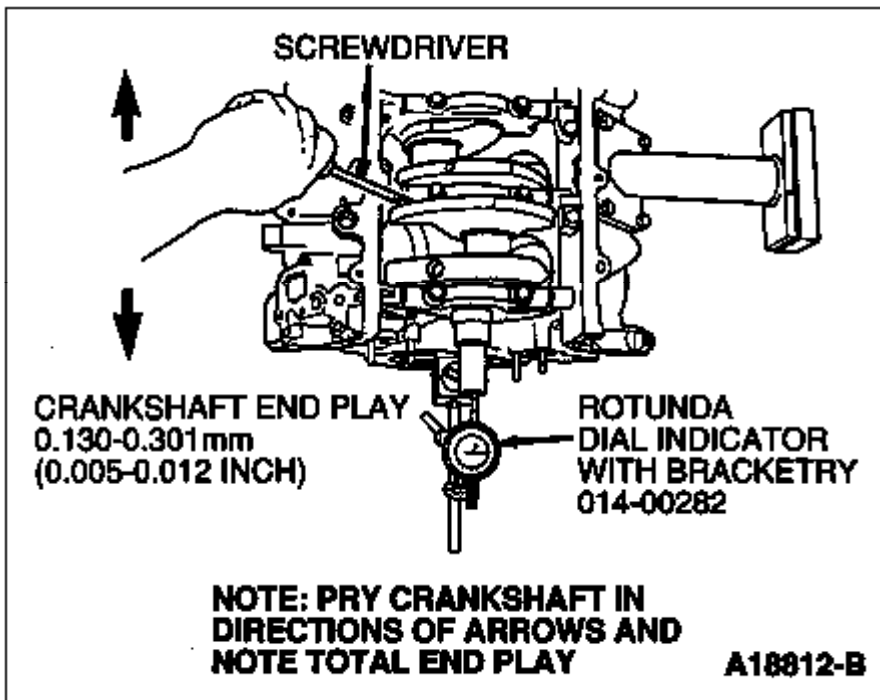

18. Remove all traces of oil, dirt and previously applied sealant from the cylinder block and retainer sealing surfaces. Sealing surfaces must be clean and dry before applying sealant.

19. Apply a 1.5mm (0.06 inch) continuous bead of Silicone Gasket and Sealant F1AZ-19562-A (WSE-M4G320-AZ) or equivalent to cylinder block as shown.

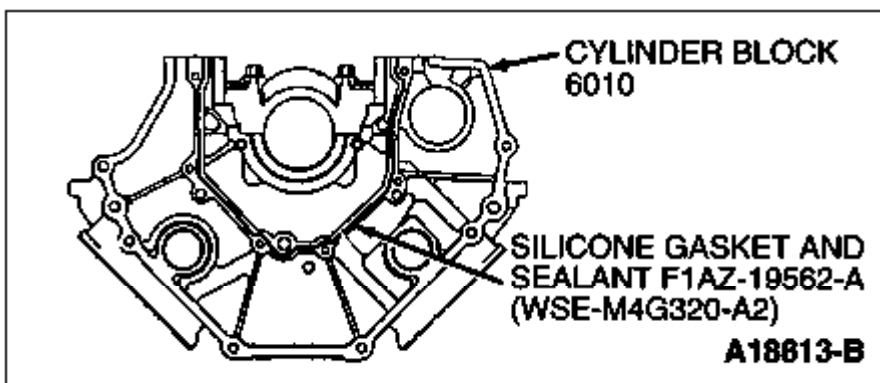

20. Install crankshaft rear oil seal and retainer to cylinder block and tighten six bolts in sequence to 8-12 N-m (70-106 lb-in) no more than four minutes after applying sealant.

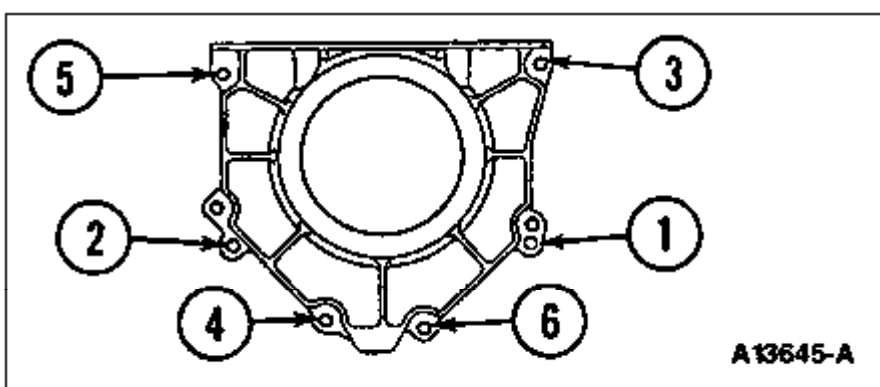

21. Using Rear Seal Installer Adapter T91P-6701-A and Rear Main Seal Installer T82L-6701-A, install crankshaft rear oil seal.

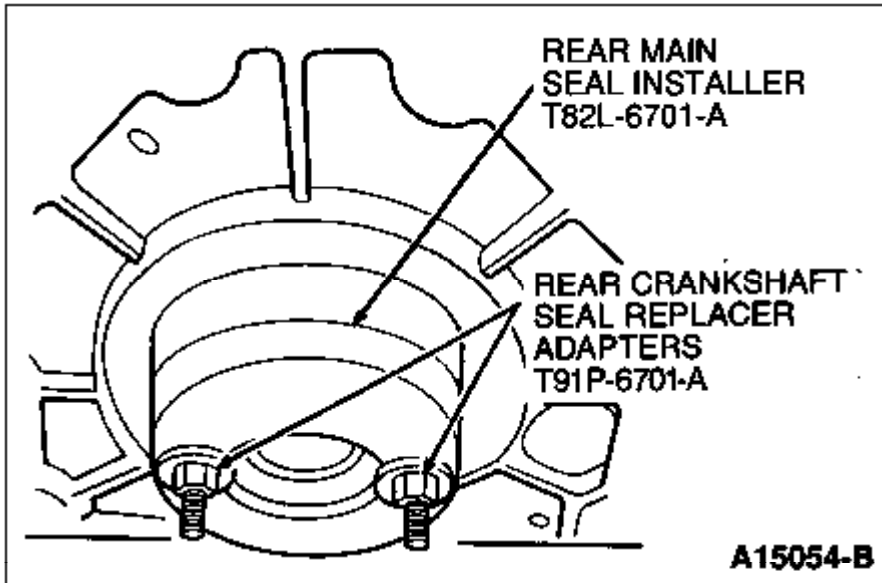

22. Install flywheel.
23. Coat piston bores, pistons and rings, crankshaft journal and bearing surfaces with clean engine oil.

NOTE:

Ensure piston ring gaps are rotated 30 degrees apart. Refer to «[Piston, Piston Pins](#)» and Rings as outlined.

24. Turn crankshaft until the crank throw is at bottom of stroke. Install correctly numbered piston and connecting rod with Piston Ring Compressor D81L-6002-C or equivalent and Piston and Rod Guide Tool T93P-6136-A.

NOTE:

Notch on piston to front of engine.

CAUTION:

Be sure not to scratch cylinder wall or crankshaft journal with connecting rod or guide tools. Push piston down until connecting rod bearing seats on crankshaft journal.

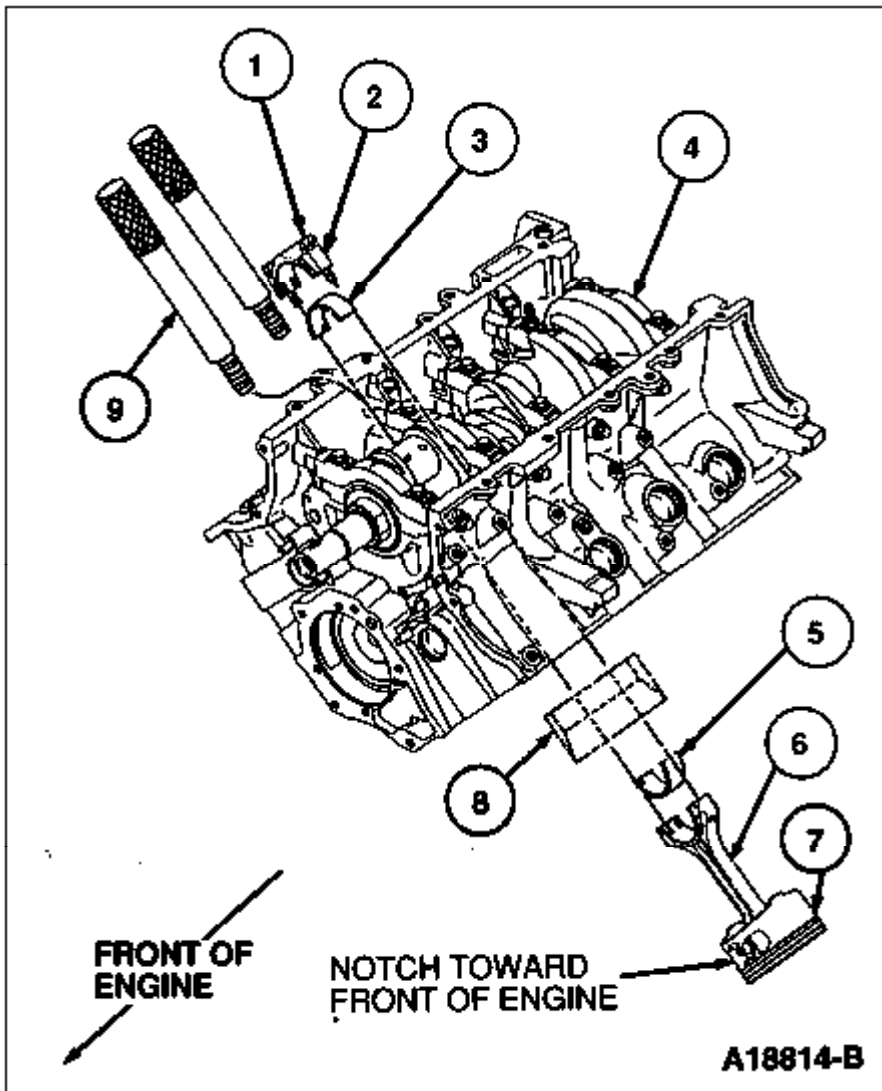

| Item | Part Number | Description |
|------|-------------|--|
| 1A | 6214 | Connecting Rod Bolt |
| 2 | - | Connecting Rod Cap (Part of 6200) |
| 3 | 6211 | Upper Connecting Rod Bearing (8 Req'd) |
| 4 | 6303 | Crankshaft |
| 5 | 6211 | Lower Connecting Rod Bearing (8 Req'd) |
| 6 | 6200 | Connecting Rod (8 Req'd) |
| 7 | 6108 | Piston (8 Req'd) |
| 8 | D81L-6002-C | Piston Ring Compressor |
| 9 | T93P-6163-A | Connecting Rod Guide Tool (2 Req'd) |
| A | | Tighten to 25-35 N-m (19-25 Lb-Ft). Rotate an additional 85-95 degrees. |

NOTE:

Due to the use of a cracked connecting rod joint face surface, it is imperative that the connecting

rod cap be properly aligned to the connecting rod. The rod connecting rod bearing tangs should be located on the same side of the connecting rod.

25. Alternately tighten new connecting rod bolts in several passes to obtain 25-35 N-m (18-25 lb-ft) and rotate connecting rod bolts an additional 85-95 degrees. After installation rotate crankshaft to ensure smooth operation.
26. Check connecting rod side clearance using Rotunda Dial Indicator with Bracketry 014-00282 or equivalent. Clearance should be 0.15-0.45mm (0.006-0.0177 inch). If side clearance is greater than maximum service limit of 0.50mm (0.020 inch), replace connecting rods and/or crankshaft.

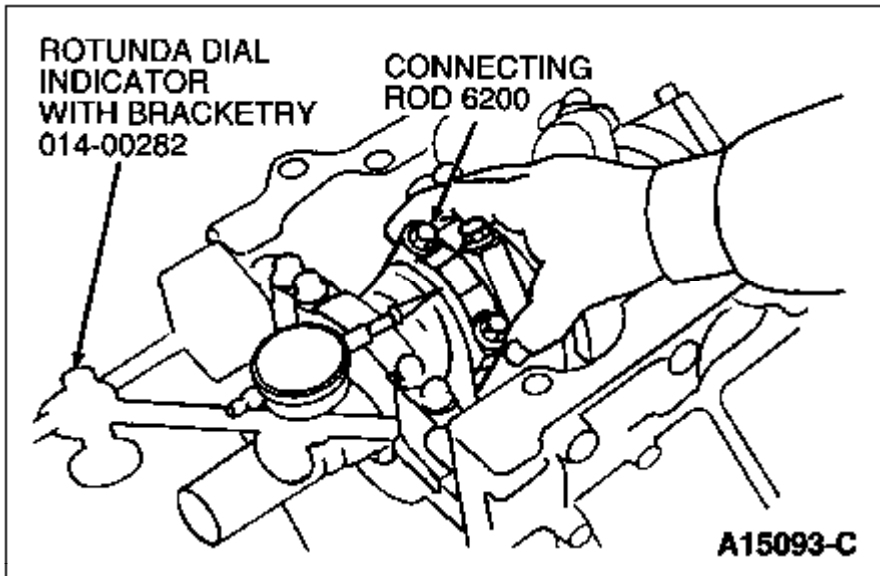

27. Install oil pump and oil pump screen cover and tube.

NOTE:

Install new O-ring on oil pump screen cover and tube, then start all bolts on oil pump and oil pump screen cover and tube before tightening.

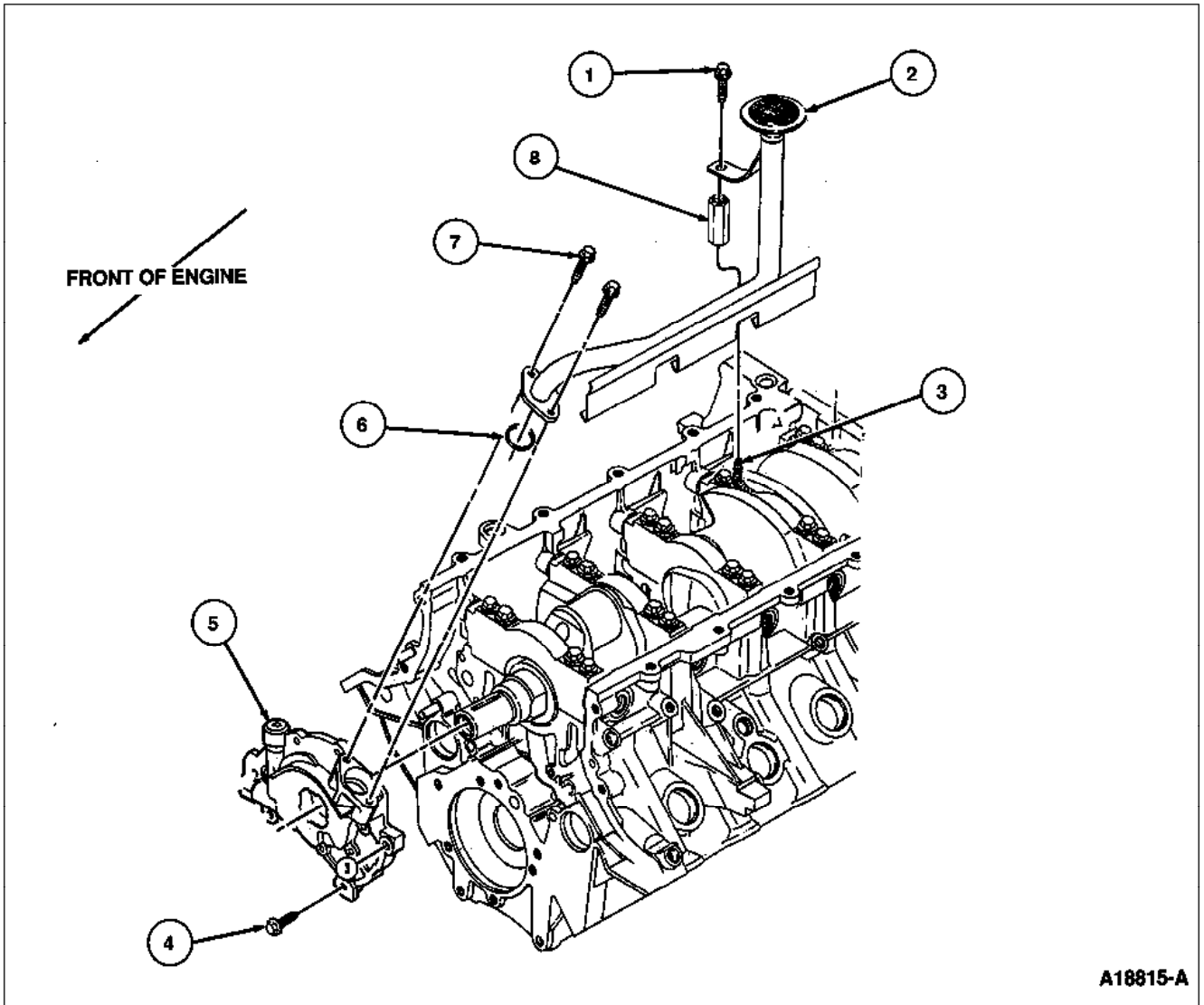

A18815-A

| Item | Part Number | Description |
|------|-------------|--|
| 1A | N605904-S | Oil Pump Screen Cover and Tube Retaining Bolt |
| 2 | 6622 | Oil Pump Screen Cover and Tube |
| 3 | 6345 | Crankshaft Main Bearing Cap Stud |
| 4B | N606021-S | Oil Pump Retaining Bolt |
| 5 | 6600 | Oil Pump |
| 6 | 87038-S96 | O-Ring |
| 7B | N606021-S | Oil Pump Screen Cover and Tube Retaining Bolts (2 Req'd) |
| 8A | M1A100 | Spacer |
| A | | Tighten to 20-30 N-m (15-22 Lb-Ft) |
| B | | Tighten to 8-12 N-m (70-106 Lb-In) |

28. Clean oil filter adapter gasket surface with clean cloth. If scraping is required, use a plastic-tipped

scraper on the aluminum surface.

NOTE:

The oil filter adapter gasket is a premium gasket and only requires replacement if the rubber surfaces are torn or if the plastic carrier is cracked. Replace oil filter adapter gasket if prior seepage was noticed. Depending on driving conditions, vehicle age, etc., the silicone may no longer be resilient or may be hardened. In these cases, the oil filter adapter gasket should be replaced.

29. Install oil filter adapter and tighten to 20-30 N-m (15-22 lb-ft).

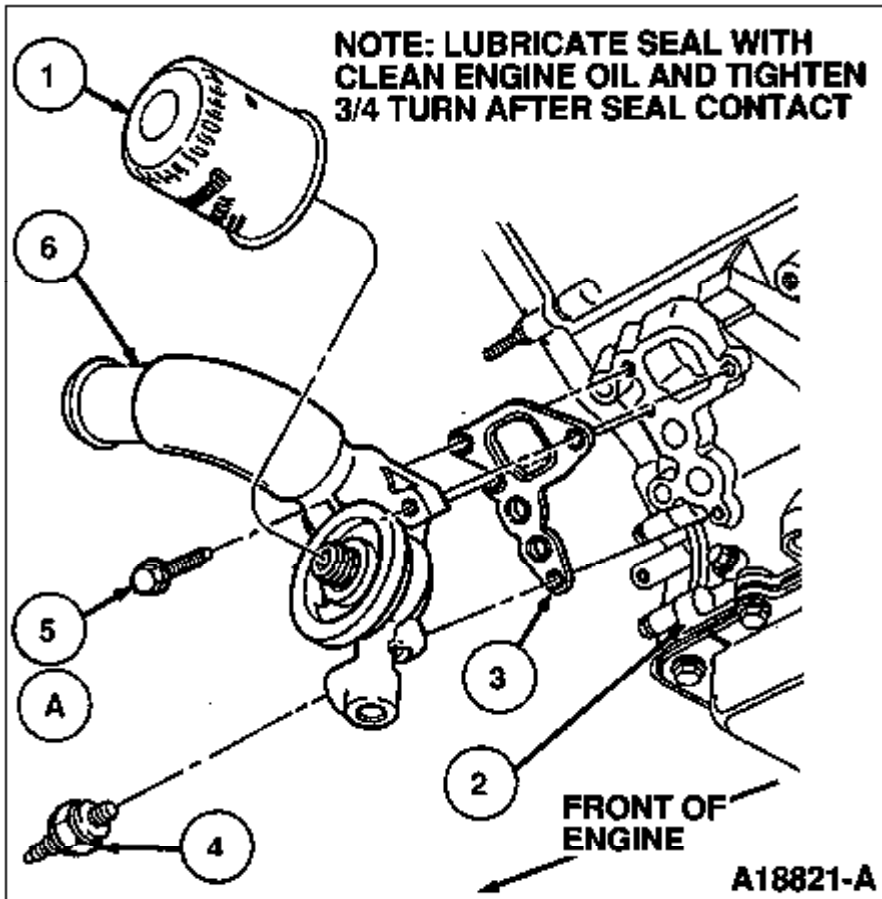

| Item | Part Number | Description |
|------|-------------|------------------------------------|
| 1 | 6714 | Oil Bypass Filter |
| 2 | 6010 | Cylinder Block |
| 3 | 6840 | Oil Filter Adapter Gasket |
| 4 | 9278 | Oil Pressure Sender |
| 5A | N806156-S2 | Bolt (4 Req'd) |
| 6 | 6881 | Oil Filter Adapter |
| A | | Tighten to 20-30 N-m (15-22 Lb-Ft) |

30. Install new oil bypass filter.

31. Install oil pressure sender, if removed. Tighten to 12-16 N-m (9-12 lb-ft).

32. Install new oil pan gasket on oil pan and place on cylinder block. Install 12 oil pan bolts and tighten

to 20-30 N·m (15-22 lb·ft).

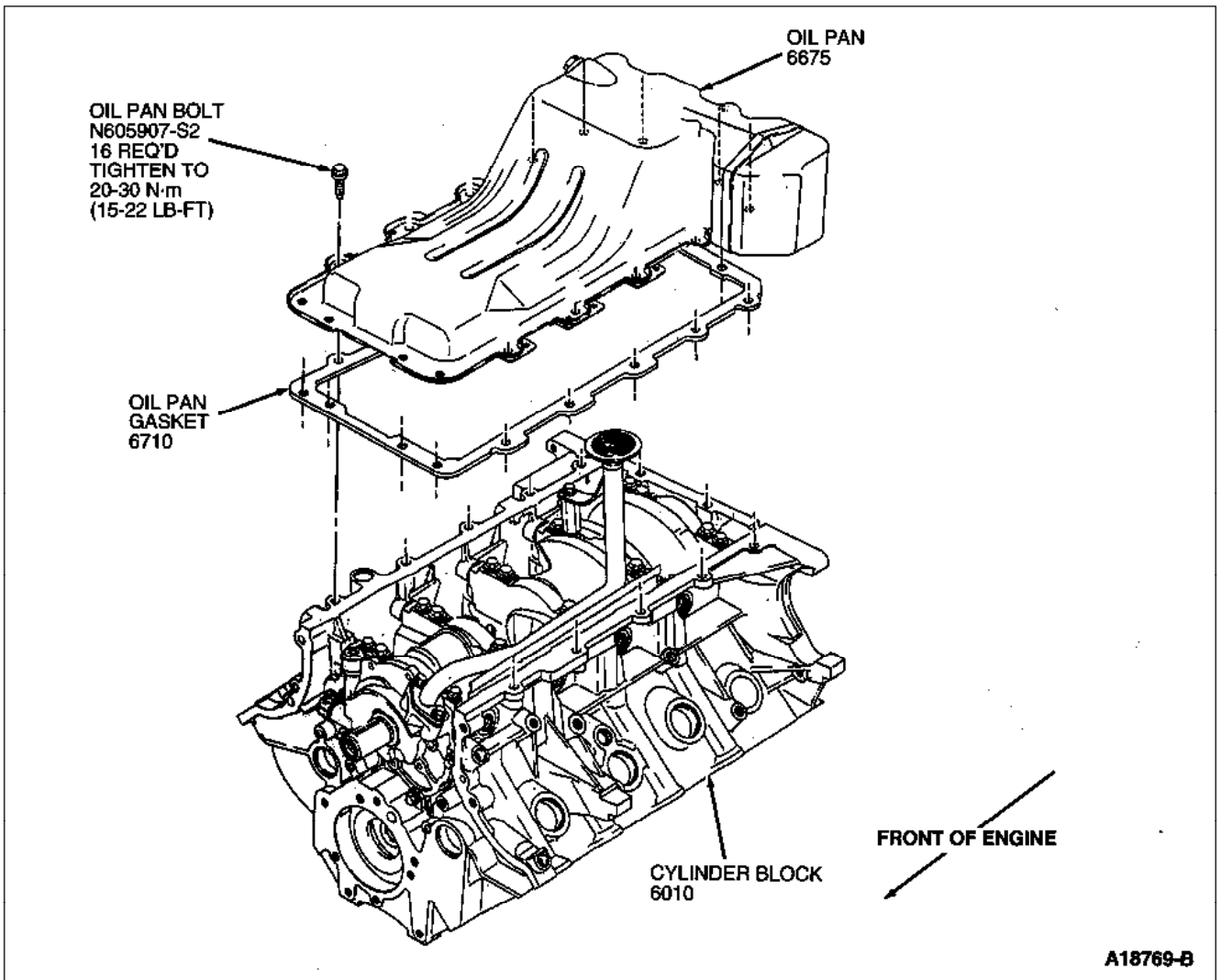

33. If cylinder heads are to be serviced, refer to «[Cylinder Head](#)» Disassembly and Assembly.

NOTE:

Ensure cylinder heads are installed in their original positions.

NOTE:

Clean cylinder head gasket surface with a toluene-based paint thinner or gasket remover. If gasket material remains on head after cleaning, use a plastic-tipped scraper and Scotch Brite® or 600 grit sandpaper to remove remaining material.

CAUTION:

Do not use sandpaper courser than 600 grit.

NOTE:

RH and LH head gaskets are not interchangeable.

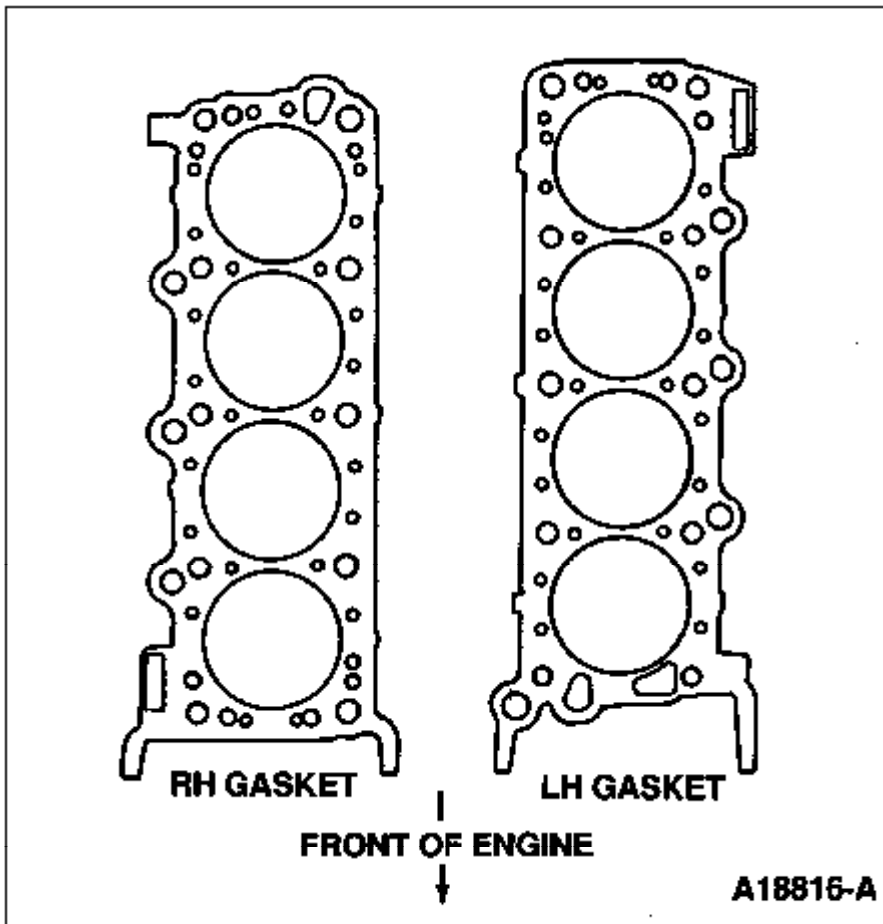

34. Position new head gaskets on cylinder block. Apply local pressure around dowel hole in head gasket to snap-fit head gasket in place.

RH Side Shown, LH Side Similar

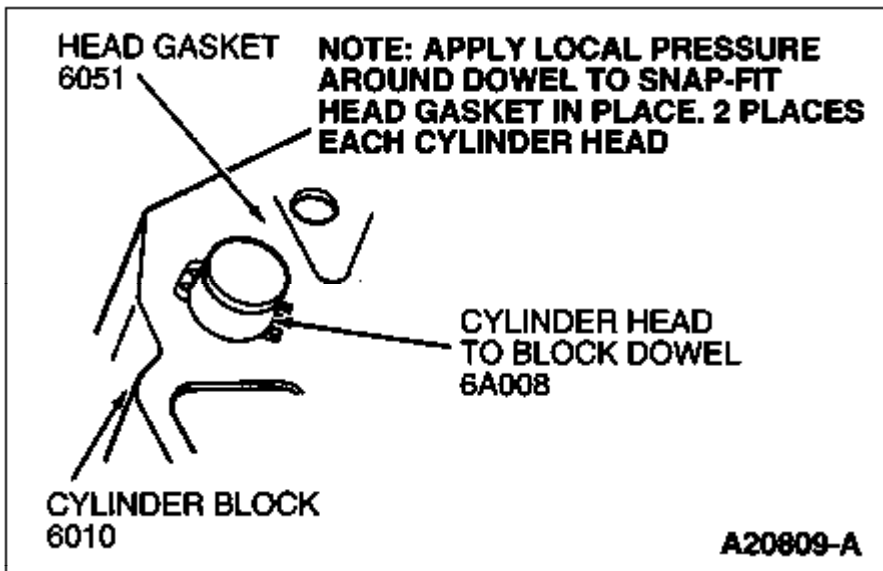

35. Rotate crankshaft to position as shown.

NOTE:

With crankshaft in this position, no piston will be at TDC.

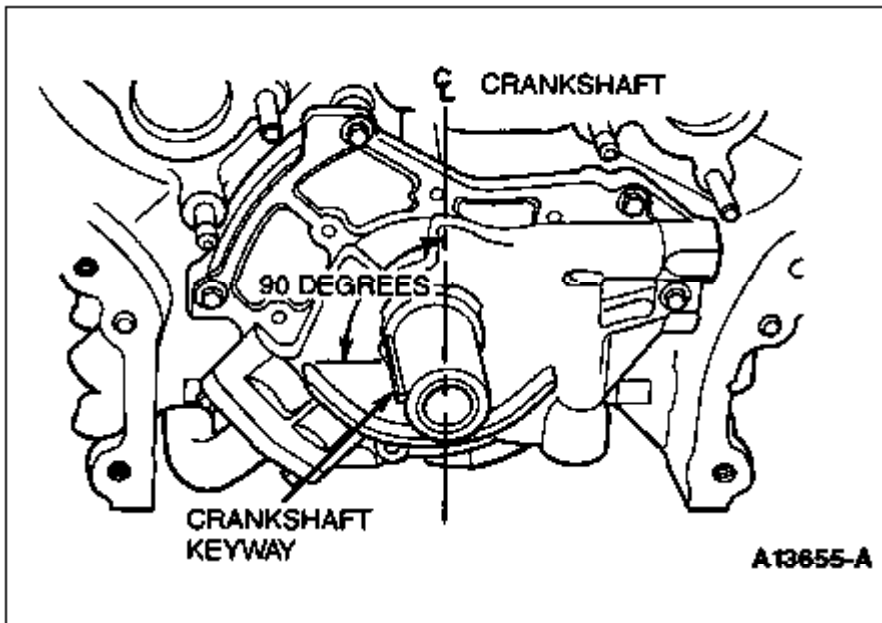

CAUTION:

With rocker arms installed, failure to position crankshaft as shown will cause damage to piston and/or valve train components.

CAUTION:

Use care when positioning cylinder heads. Damage to cylinder block and/or cylinder heads may result.

36. Position cylinder heads on cylinder block.

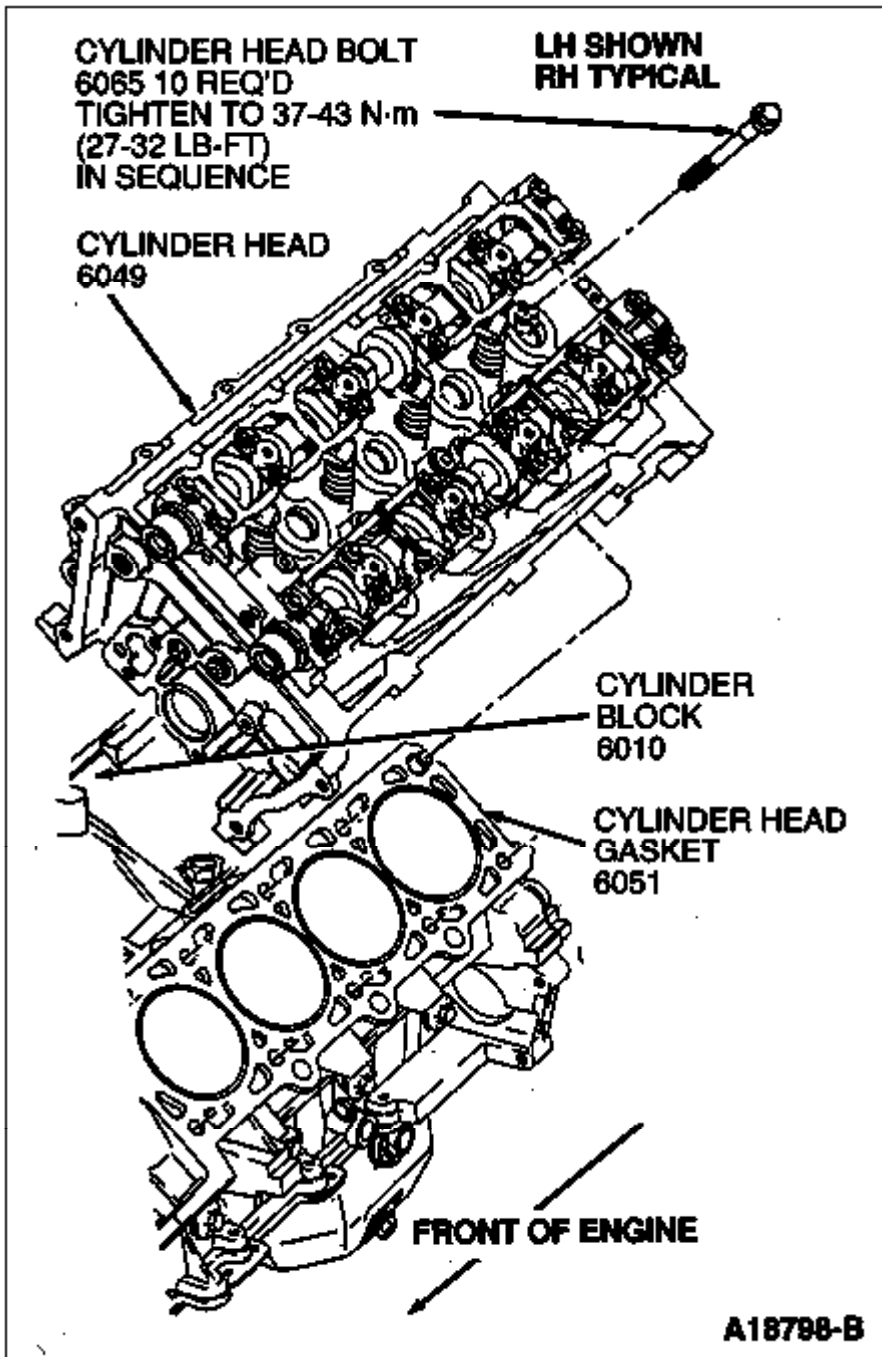

NOTE:

Apply clean engine oil to all head bolt washers and threads.

CAUTION:

Cylinder head bolts must be replaced with new bolts. They are torque-to-yield designed and cannot be reused.

37. Tighten new cylinder head bolts as follows:

- a. Tighten head bolts in sequence to 37-43 N·m (27-32 lb-ft).
- b. Rotate head bolts in sequence 85-95 degrees clockwise.
- c. Rotate head bolts in sequence an additional 85-95 degrees clockwise.

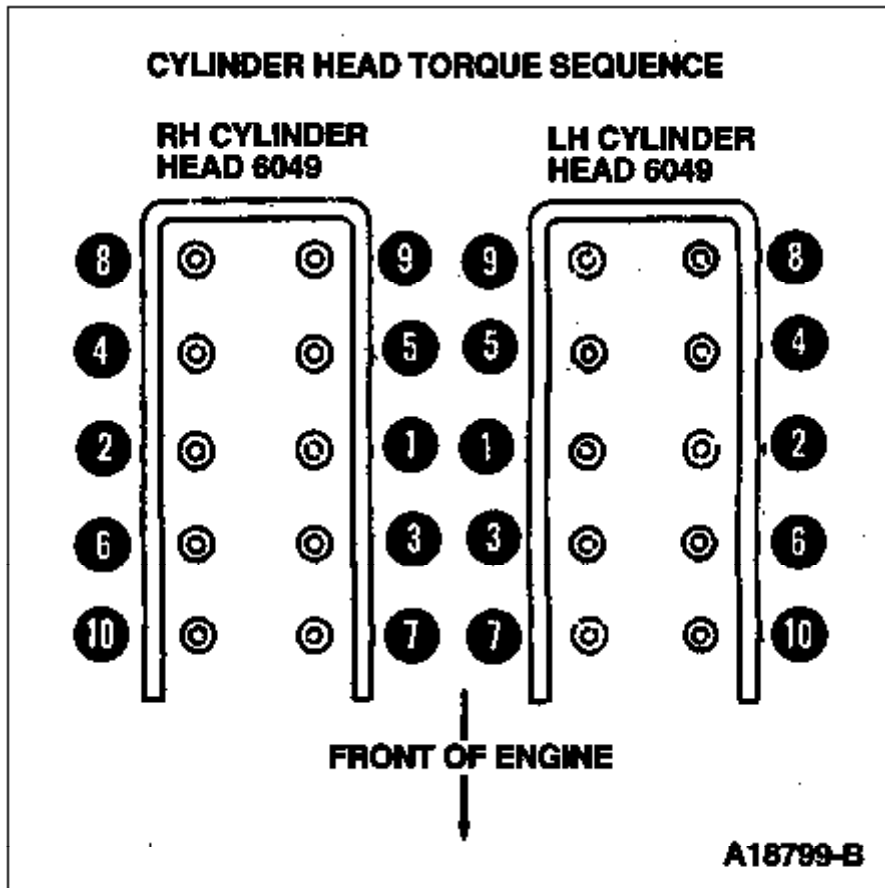

38. Rotate crankshaft clockwise 45 degrees. This will position crankshaft at TDC No. 1.

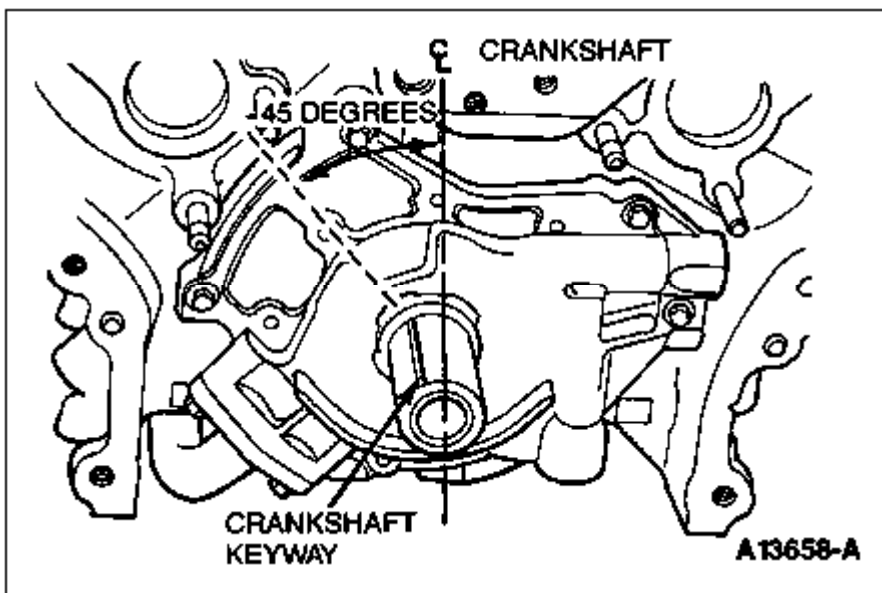

CAUTION:

Crankshaft must only be rotated in the clockwise direction and only as far as TDC No. 1.

39. Install timing chains as outlined.
40. Install heater water hose and clamp onto cylinder block connection.
41. Install heater water hose brackets to cylinder head using two stud bolts and tighten to 20-30 N-m (15-22 lb-ft).
42. After removing all traces of oil, dirt and previously applied sealant from engine front cover, cylinder heads and cylinder block sealing surfaces, replace crankshaft front seal and install new engine timing cover gaskets. No adhesive is required.

NOTE:

Sealing surfaces must be clean and dry before applying sealant.

43. Apply Silicone Gasket and Sealant F1AZ-19562-A (WSE-M4G320-A2) or equivalent to six places on front of engine.

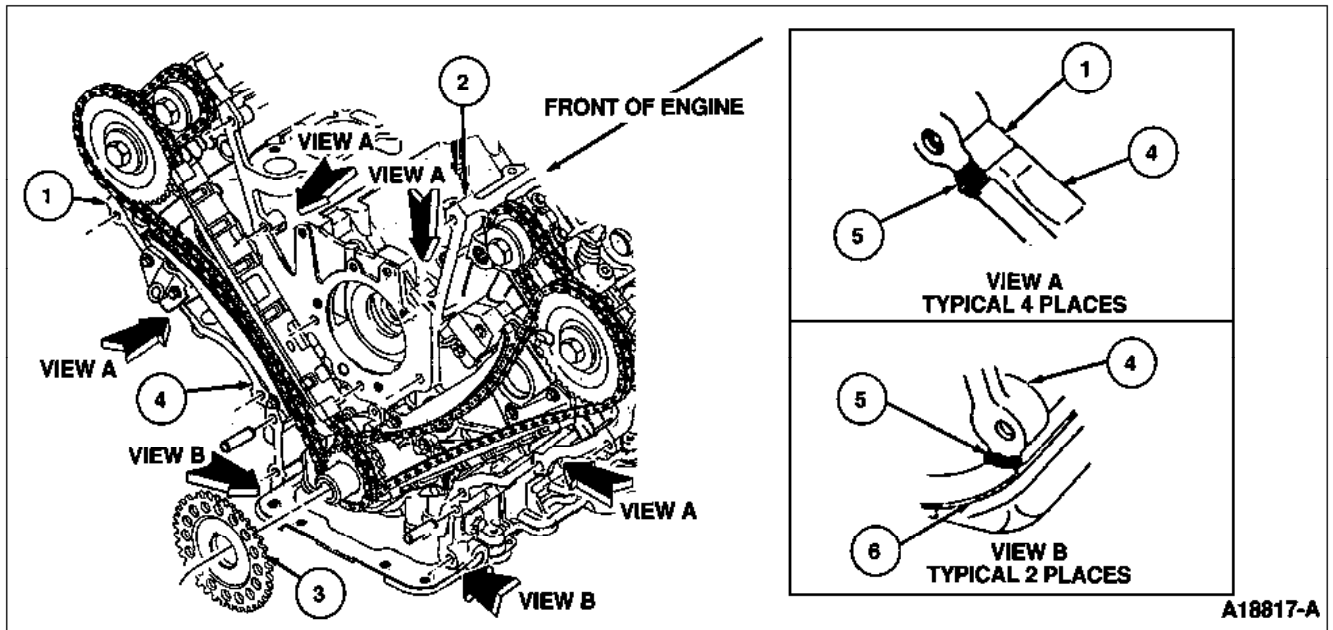

A18817-A

| Item | Part Number | Description |
|------|---------------|--|
| 1 | 6049 | RH Cylinder Head |
| 2 | 6049 | LH Cylinder Head |
| 3 | 12A227 | Crankshaft Position Sensor Pulse Wheel |
| 4 | 6010 | Cylinder Block |
| 5 | WSE-M4G323-A1 | Sealer |
| 6 | 6710 | Oil Pan Gasket |

44. Install crankshaft position sensor pulse wheel.

NOTE:

Engine front cover must be rolled into position. Do not slide on oil pan gasket.

45. Install engine front cover.

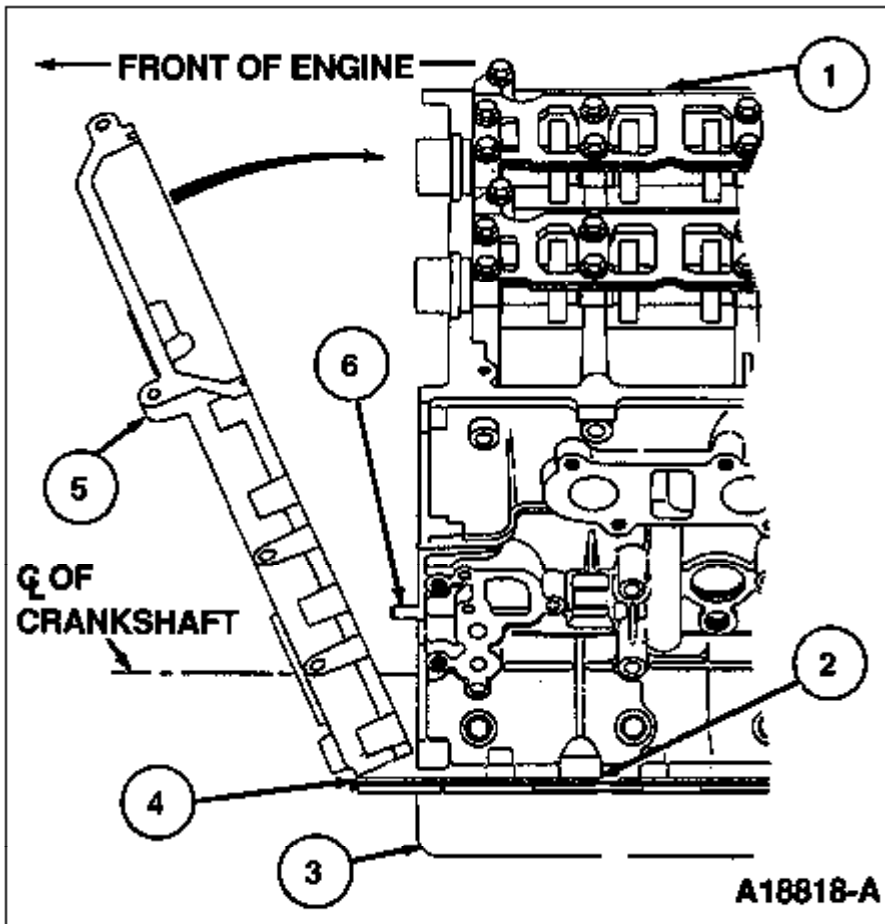

| Item | Part Number | Description |
|------|-------------|--------------------|
| 1 | 6049 | LH Cylinder Head |
| 2 | 6010 | Cylinder Block |
| 3 | 6675 | Oil Pan |
| 4 | 6710 | Oil Pan Gasket |
| 5 | 6019 | Engine Front Cover |

46. Install eight bolts and seven stud bolts. Tighten in sequence to 20-30 N-m (15-22 lb-ft). Tighten stud bolts and bolts number six, seven, eight, nine, ten and eleven in no more than four minutes after applying sealant.

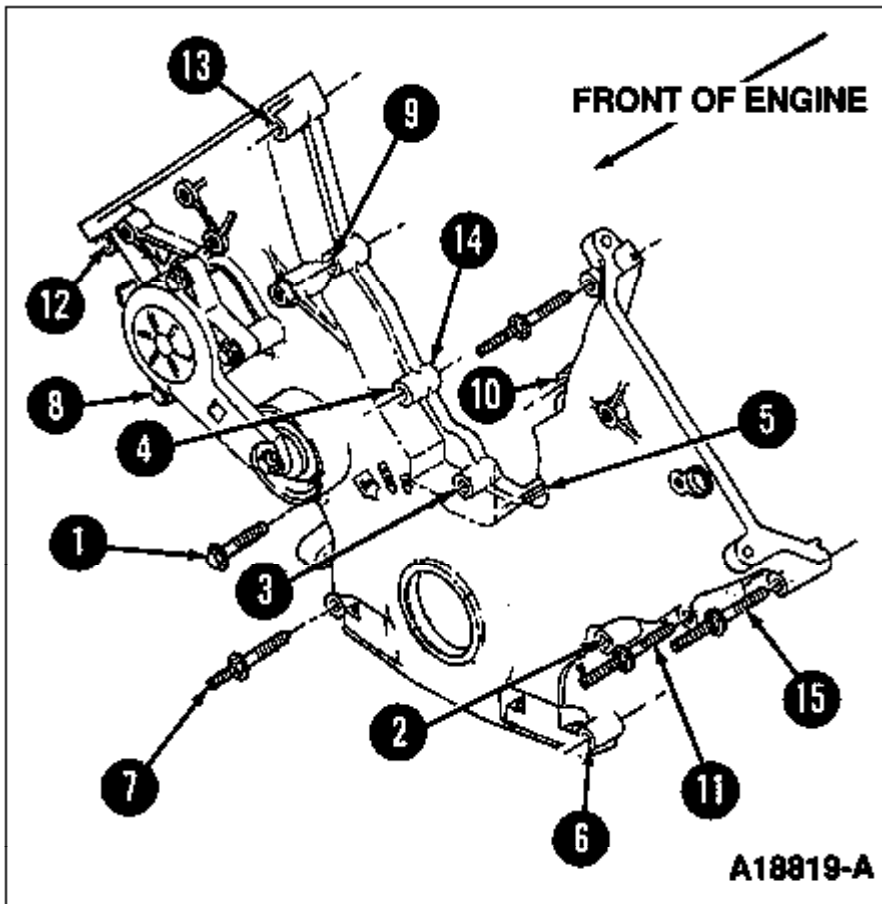

47. Install water pump and tighten retaining bolts to 20-30 N-m (15-22 lb-ft).
48. Install knock sensor harness assembly.
49. Install crankshaft position sensor and camshaft position sensor into engine front cover and tighten retaining bolts to 8-12 N-m (70-106 lb-in).
50. Install four bolts retaining oil pan to engine front cover and tighten to 20-30 N-m (15-22 lb-ft).

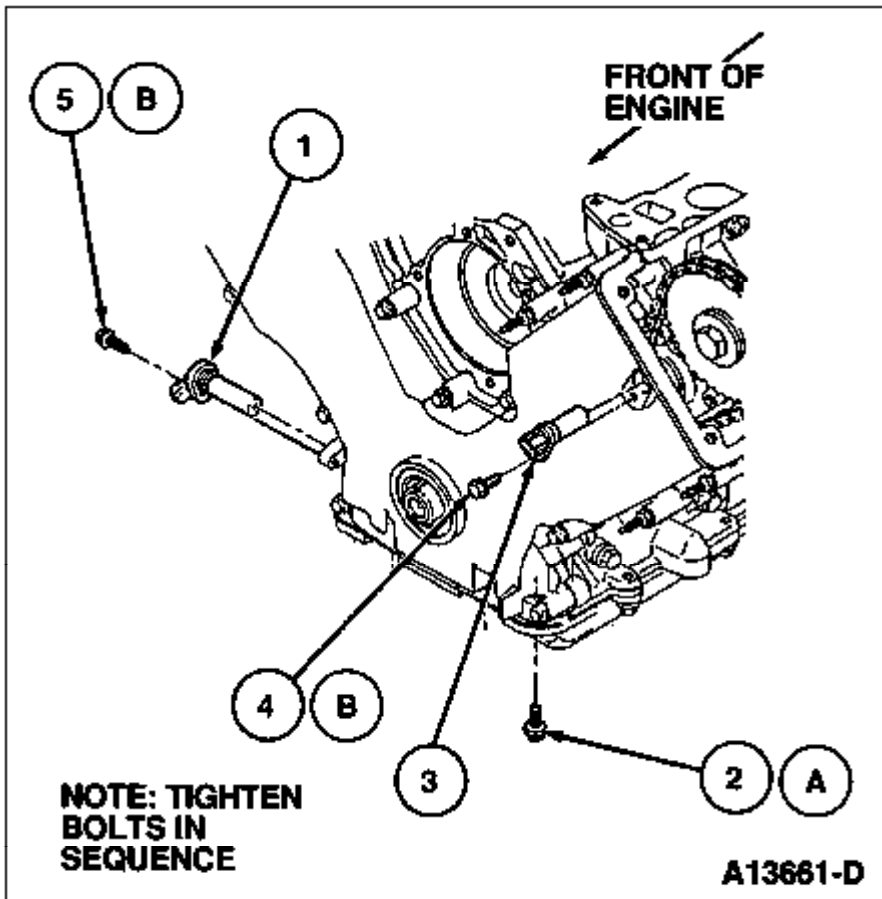

| Item | Part Number | Description |
|------|-------------|------------------------------------|
| 1 | 6C315 | Crankshaft Position Sensor |
| 2A | - | Bolt (4 Req'd) |
| 3 | 6B288 | Camshaft Position Sensor |
| 4B | - | Screw and Washer Assy |
| 5B | - | Screw and Washer Assy |
| A | | Tighten to 20-30 N-m (15-22 Lb-Ft) |
| B | | Tighten to 8-12 N-m (70-106 Lb-In) |

NOTE:

Silicone Gasket and Sealer F1AZ-19562-A (WSE-M4G320-A2) or equivalent must be applied to crankshaft keyway prior to installing crankshaft pulley.

51. Install crankshaft pulley using Crankshaft Damper Replacer T74P-6316-B.

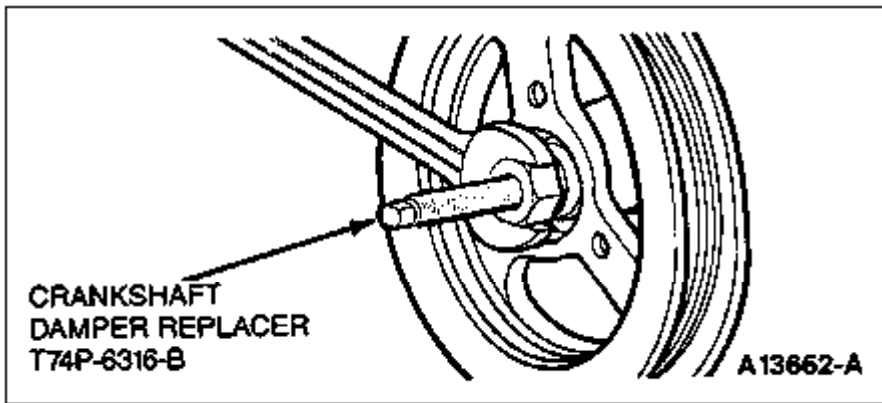

52. Install crankshaft pulley retaining bolt and washer. Tighten to 155-165 N-m (114-121 lb-ft).
53. Clean sealing surfaces of cylinder head and valve covers. Remove all traces of oil, dirt and previously applied sealant from engine front cover and cylinder heads. Sealing surfaces must be clean and dry before applying sealant.
54. Position and, using a suitable adhesive, glue new perimeter gaskets into valve covers. Replace spark plug bore to valve cover gaskets. No adhesive is required.
55. Apply Silicone Gasket and Sealer F1AZ-19562-A (WSE-M4G320-A2) or equivalent in four places where engine front cover meets cylinder heads and install valve covers into cylinder heads.
56. On RH valve cover, install bolts and stud bolts into valve cover. Tighten bolts and studs in sequence to 8-12 N-m (70-106 lb-in).
57. On LH valve cover, install bolts and stud bolts into valve cover. Tighten bolts and studs in sequence to 8-12 N-m (70-106 lb-in) no more than four minutes after applying sealant.

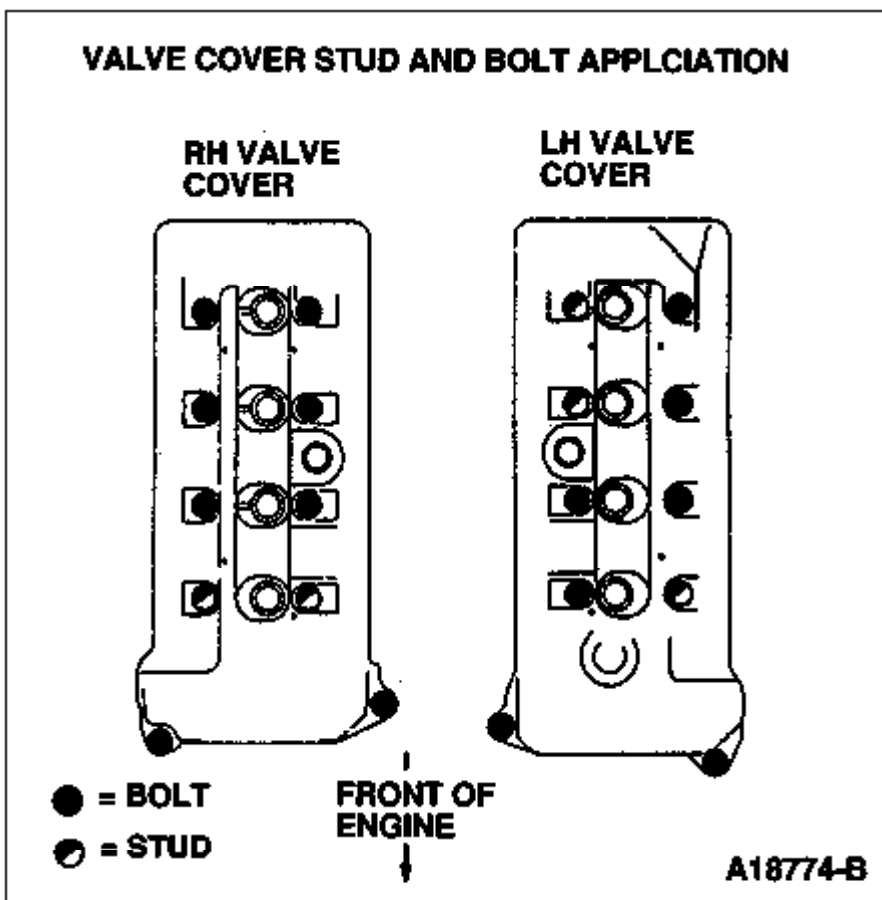

58. Clean and inspect all sealing surfaces. Upper sealing surfaces of IMRC units and intake manifold mating surfaces should be cleaned with a suitable solvent to remove adhesive residue. Inspect intake manifold mating surfaces and upper IMRC surfaces to ensure that no load limiting spacers

(washers) are stuck to the sealing surfaces. The load limiting spacers are part of the intake manifold upper gasket. New load limiter spacers will be included with the replacement intake manifold upper gasket as an assembly.

59. Remove protective paper from adhesive backing on intake manifold upper gasket and install onto top of RH IMRC unit using tapered pins at end bolt hole locations for proper gasket alignment. Repeat procedure for LH IMRC unit.
60. Sub-assemble IMRC units to intake manifold and install four IMRC retaining bolts. Finger-tighten bolts.
61. Lubricate fuel injector O-rings with engine oil or equivalent prior to assembly. Install fuel injectors into IMRC units.
62. Install fuel injection supply manifold onto fuel injectors and install four retaining screws. Tighten to 3-5 N-m (26-45 lb-in). Install two fuel pressure regulator bracket retaining screws. Tighten to 8-12 N-m (70-106 lb-in).

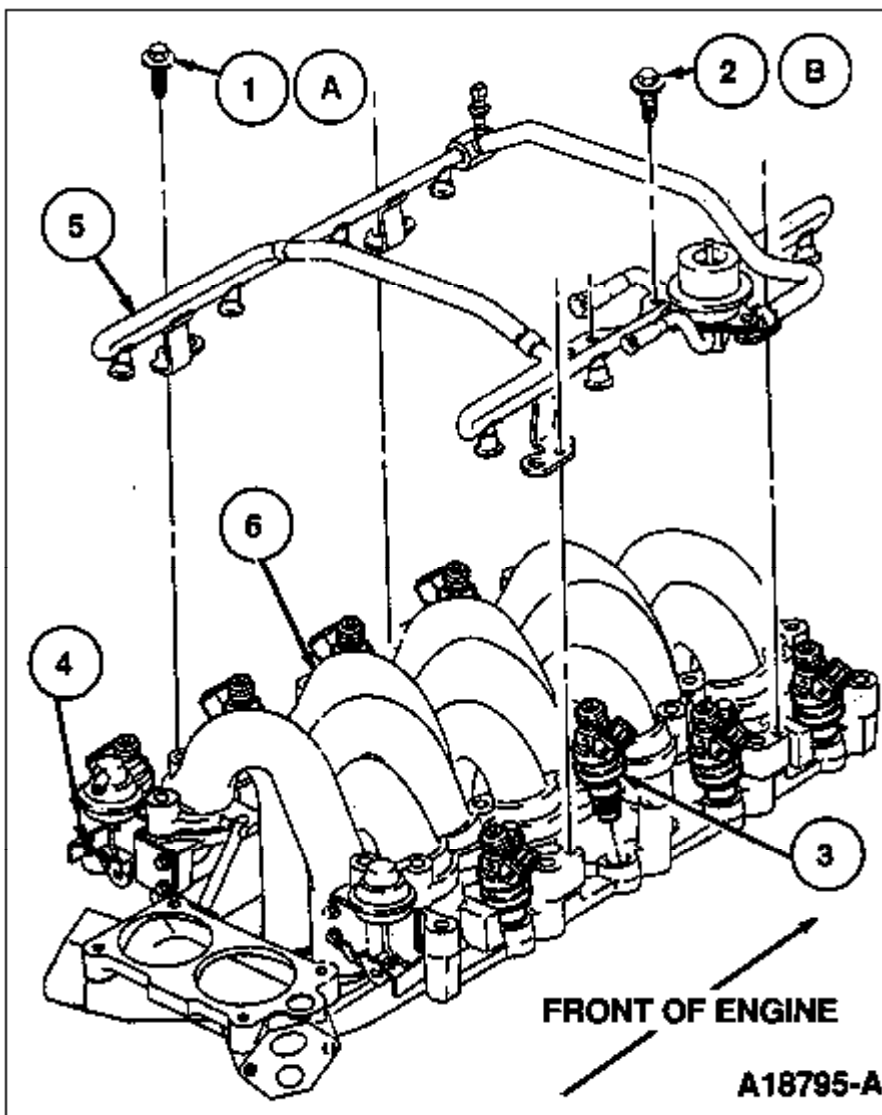

| Item | Part Number | Description |
|------|-------------|---|
| 1A | N804394-S8M | Fuel Injection Supply Manifold Retaining Bolt (4 Req'd) |
| 2B | N804394-S8M | Fuel Pressure Regulator Retaining Bolt (12 Req'd) |

| | | |
|---|-------|---|
| 3 | 9F593 | Fuel Injector (8 Req'd) |
| 4 | 9U531 | Intake Manifold Runner Control (IMRC) (2 Req'd) |
| 5 | 9F792 | Fuel Injection Supply Manifold |
| 6 | 9424 | Intake Manifold |
| A | | Tighten to 3-5 N-m (26-45 Lb-In) |
| B | | Tighten to 8-12 N-m (70-106 Lb-In) |

63. If removed, install new idle air control gasket (9F670), and tighten retaining bolt and stud bolt to 8-12 N-m (70-106 lb-in).
64. If removed, install throttle body and new throttle body gasket (9E936). Tighten four retaining bolts to 8-12 N-m (70-106 lb-in).
65. Position new IMRC gaskets onto cylinder heads using gaskets' integral locating pins to align gaskets.
66. Place intake manifold onto engine.
67. Install ten longer length bolts and stud bolts in outer bolt holes of intake manifold. Do not tighten.
68. Install ten shorter length bolts and stud bolts in inner bolt holes of intake manifold. Hand tighten all 20 fasteners.
69. Tighten fasteners 1-20 in numerical sequence as follows:
 - Fasteners 5, 7, 9 and 11 to 12-15 N-m (8.8-11.0 lb-ft)
 - All other fasteners to 18-22 N-m (13-16 lb-ft)
 - Then tighten all fasteners in numerical sequence by rotating an additional 85-95 degrees.

Intake Manifold Torque Sequence

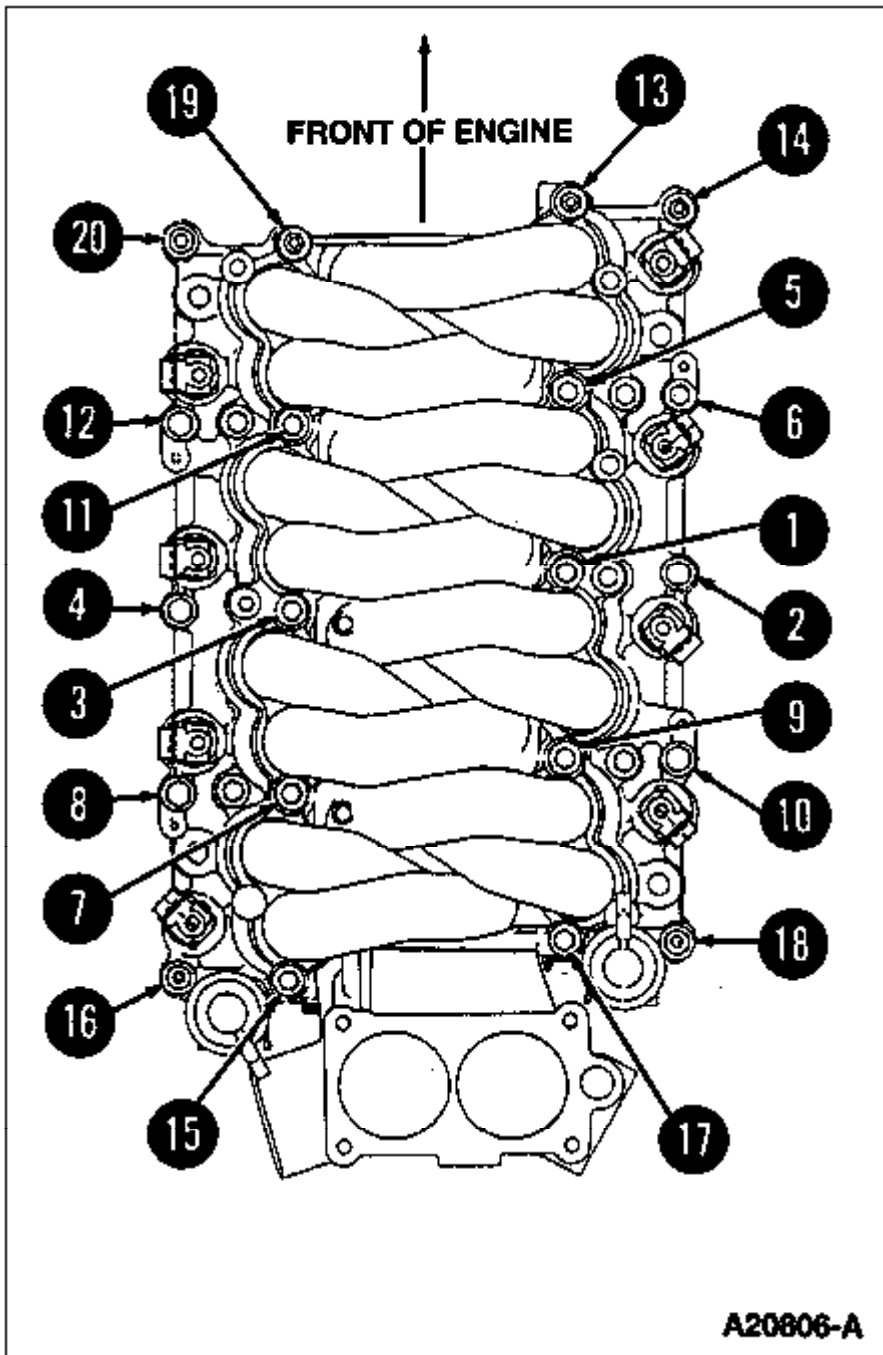

70. Tighten four intake manifold to IMRC retaining bolts to 8-10 N-m (6-7.5 lb-ft). Tighten fasteners A through D in sequence shown by rotating 85-95 degrees.

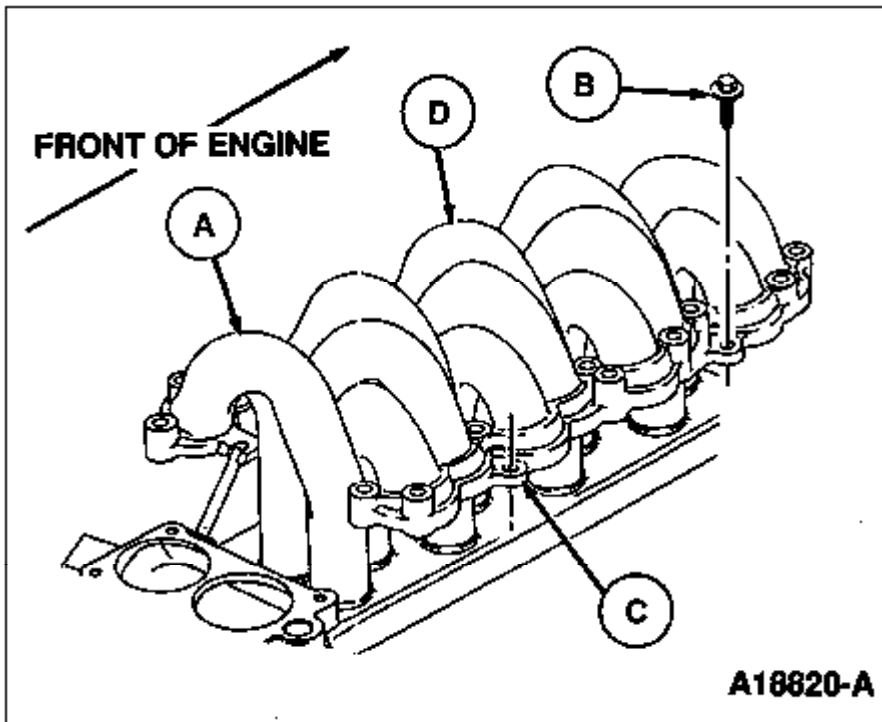

71. Replace O-ring seals on water bypass tube as required. Replace center O-ring seal on water bypass tube if needed.
72. Clean O-ring sealing surface on cylinder heads and water bypass tube sealing O-rings with antifreeze. Insert water bypass tube support braces over intake manifold inner studs and press water bypass tube into position.

CAUTION:

Do not cut O-ring seal during water bypass tube installation into cylinder heads.

73. Install two water bypass tube retaining nuts and tighten to 8-12 N-m (70-106 lb-in).

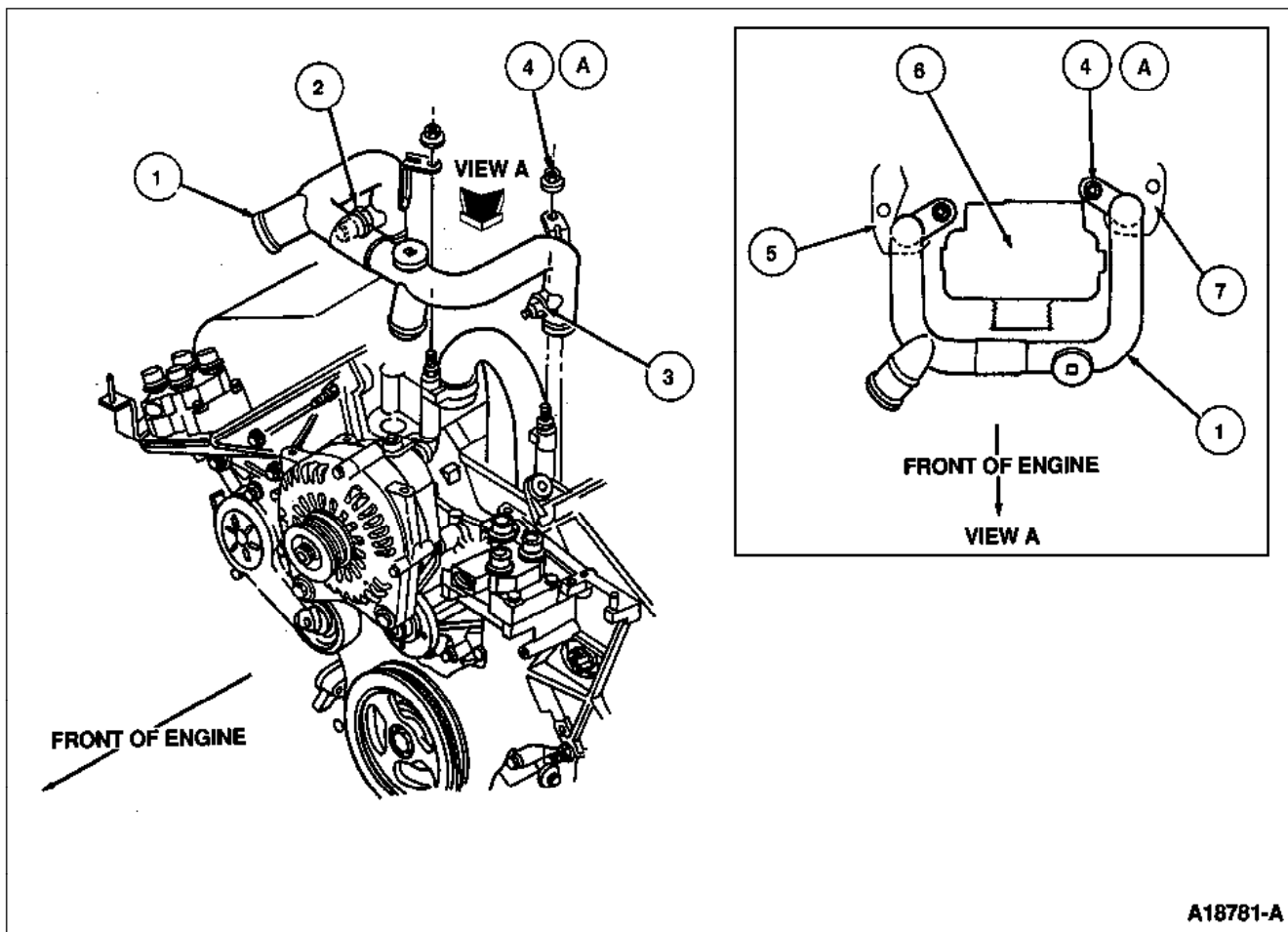

A18781-A

| Item | Part Number | Description |
|------|-------------|---|
| 1 | 8548 | Water Bypass Tube |
| 2 | 12A648 | Engine Coolant Temperature Sensor |
| 3 | 10884 | Water Temperature Indicator Sender Unit |
| 4A | N807309-S2 | Water Bypass Tube Retaining Nut |
| 5 | 6049 | RH Cylinder Head |
| 6 | 10300 | Generator |
| 7 | 6049 | LH Cylinder Head |
| A | | Tighten to 8-12 N-m (70-106 Lb-In) |

74. Verify conductivity of water temperature indicator sender unit using Rotunda Digital Volt-Ohmmeter 007-00001 or equivalent. Touch body of water temperature indicator sender unit with probe and other probe to ground. If more than 1 ohm resistance, remove water bypass tube and remove paint on bottom of mounting tabs.
75. Position LH ignition coil bracket onto mounting studs and install three retaining nuts and one bolt. Tighten to 20-30 N-m (15-22 lb-ft).
76. Position RH ignition coil bracket and install three retaining bolts. Tighten to 20-30 N-m (15-22 lb-ft).
77. Install RH exhaust manifold and new gasket. Install eight retaining bolts and tighten to 20-30 N-m

(15-22 lb-ft).

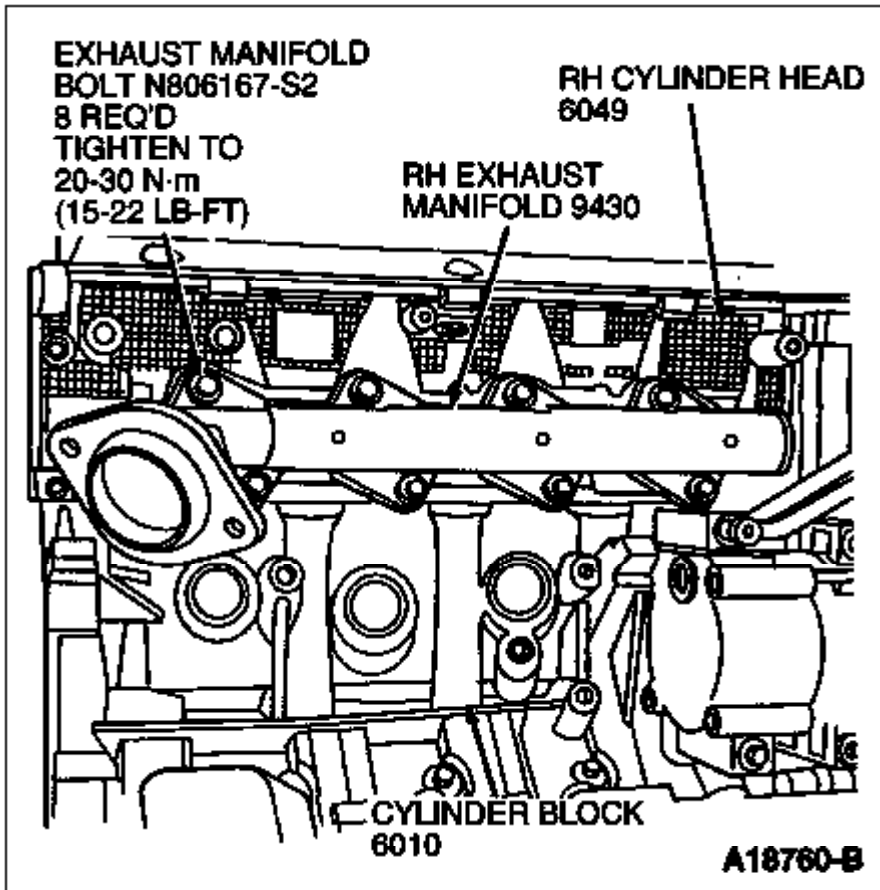

78. Install A/C compressor and tighten three retaining bolts to 20-30 N-m (15-22 lb-ft).
79. Install water pump pulley and finger-tighten four retaining bolts.
80. Install generator and tighten bolts to 20-30 N-m (15-22 lb-ft).
81. Install generator mounting bracket, two retaining bolts and two stud bolts. Tighten to 8-12 N-m (70-106 lb-in).
82. Install crankcase vent connector and hose to LH valve cover and throttle body.

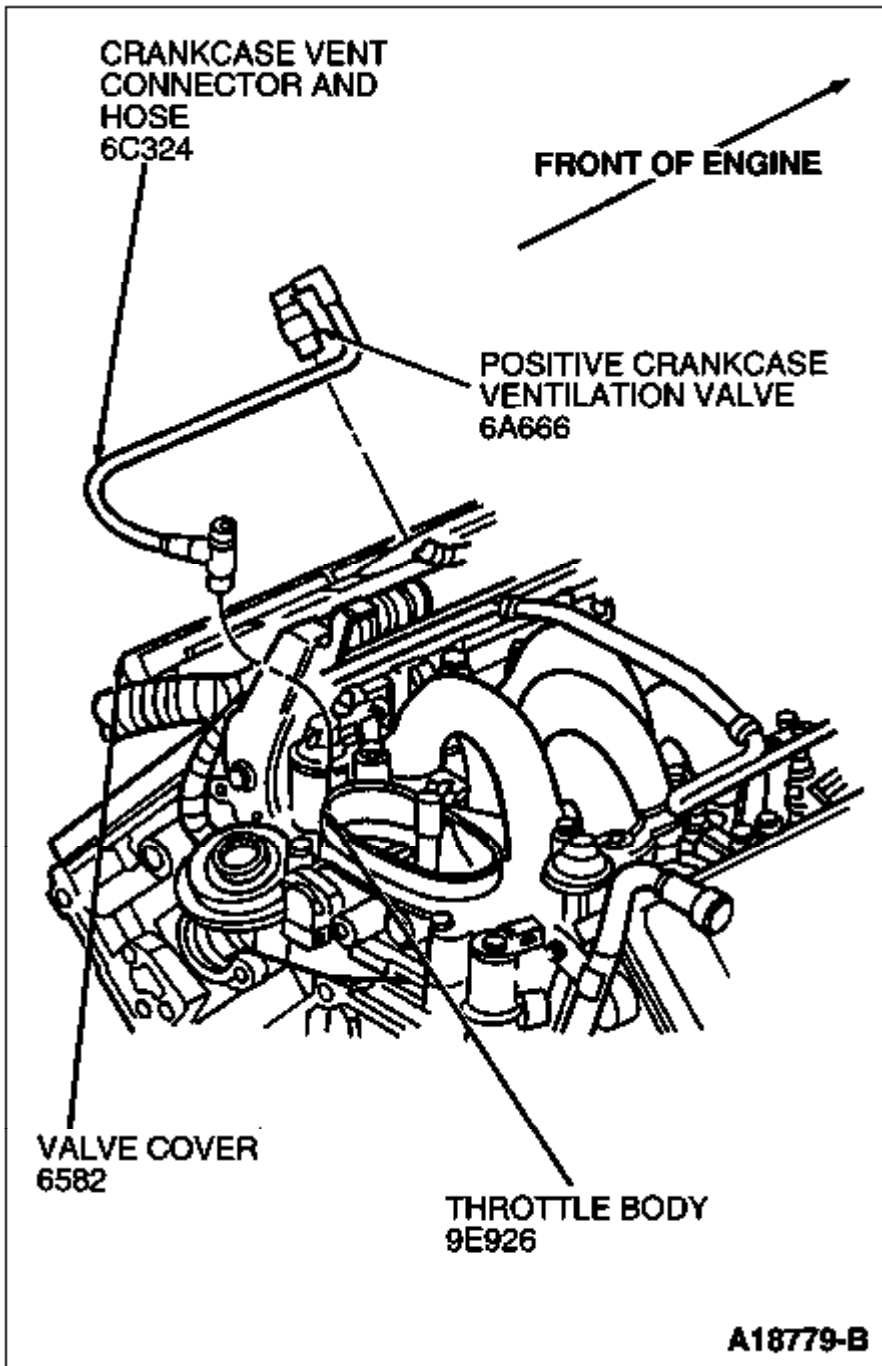

83. Insert oil level indicator tube assembly into cylinder block and install LH valve cover retaining nut to retain oil level indicator tube. Tighten nut to 8-12 N-m (70-106 lb-in).

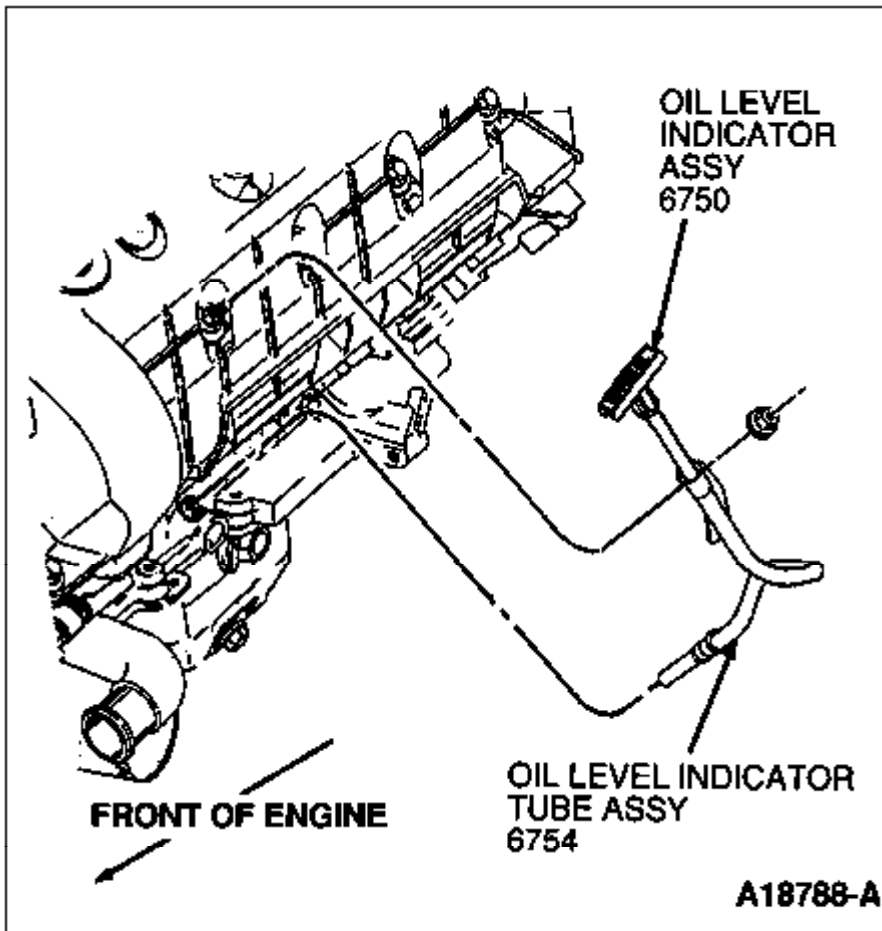

84. Install engine air cleaner outlet tube bracket and retaining nuts on RH valve cover. Tighten retaining nuts to 8-12 N-m (70-106 lb-in).
85. Install EGR control valve and new EGR valve gasket. Tighten to 20-30 N-m (15-22 lb-ft).
86. Install water inlet tube on rear of RH cylinder head. Install two retaining bolts and one retaining nut. Tighten to 8-12 N-m (70-106 lb-in).
87. Install accelerator cable bracket and two retaining bolts. Tighten bolts to 20-30 N-m (15-22 lb-ft).
88. Install power steering pump and tighten four retaining bolts to 20-30 N-m (15-22 lb-ft).
89. Install power steering reservoir to LH ignition coil bracket and install one stud and one bolt. Tighten to 8-12 N-m (70-106 lb-in). Attach reservoir supply hose to power steering pump and clamp.
90. Install water thermostat housing assembly. Attach hoses to water bypass tube and coolant inlet connection. Clamp both hoses.
91. Install drive belt. Refer to [«Section 03-05»](#).
92. Tighten four water pump pulley bolts to 20-30 N-m (15-22 lb-ft).
93. Connect vacuum harness to fuel pressure regulator, RH and LH IMRC vacuum controls, EGR control valve, EGR vacuum regulator control and IMRC control solenoids and intake manifold connection.
94. Install engine control sensor wiring and connect all applicable wiring connectors.
95. Install eight spark plugs and tighten to 9-20 N-m (6.5-15 lb-ft).
96. Connect ignition wires to spark plugs.
97. Install ignition wire covers and retaining nuts onto valve cover studs. Tighten retaining nuts to 2-4 N-m (18-35 lb-in).

98. Connect vehicle vacuum supply hose to intake manifold connection.
 99. Install EGR solenoid bracket and vacuum supply bracket to LH valve cover studs. Install two retaining nuts and tighten to 8-12 N-m (70-106 lb-in).
 100. Install lifting eyes on RH and LH cylinder heads. Tighten to 55-65 N-m (40-48 lb-ft).
 101. Install engine as outlined.
-