



« 1994 Mark VIII Table of Contents »

«Group 03: ENGINE»

«Section 03-01: Engine, 4.6L»

«REMOVAL AND INSTALLATION»

---

## Timing Chains and Timing Sprockets and Tensioners and Guides

SPECIAL SERVICE TOOL(S) REQUIRED

Description	Tool Number
Camshaft Positioning Tool	T93P-6256-A
Camshaft Holding Tool	T93P-6256-AH
Camshaft Holding Tool	T93P-6256-AH
Tensioning Tool	T93P-6256-BH

### Removal

1. **CAUTION:** At no time, when the timing chain(s) are removed and the cylinder heads (6049) are installed, may the crankshaft (6303) and/or camshafts (6250) be rotated without following established procedures. Failure to follow these directions will result in valve and/or piston damage.

NOTE: Because this is not a free-wheeling engine, if it has "jumped time," there will be damage to the valves and/or pistons (6108) and will require the removal of the cylinder heads.

Remove engine front cover (6019) as outlined.

2. Remove rocker arms (6564) as outlined.
3. Remove crankshaft position sensor pulse wheel.
4. NOTE: Timing marks on the camshaft sprocket (6256) must be on the top of both sprockets as shown.

Rotate engine to No. 1 top dead center (TDC).

### Crankshaft Position

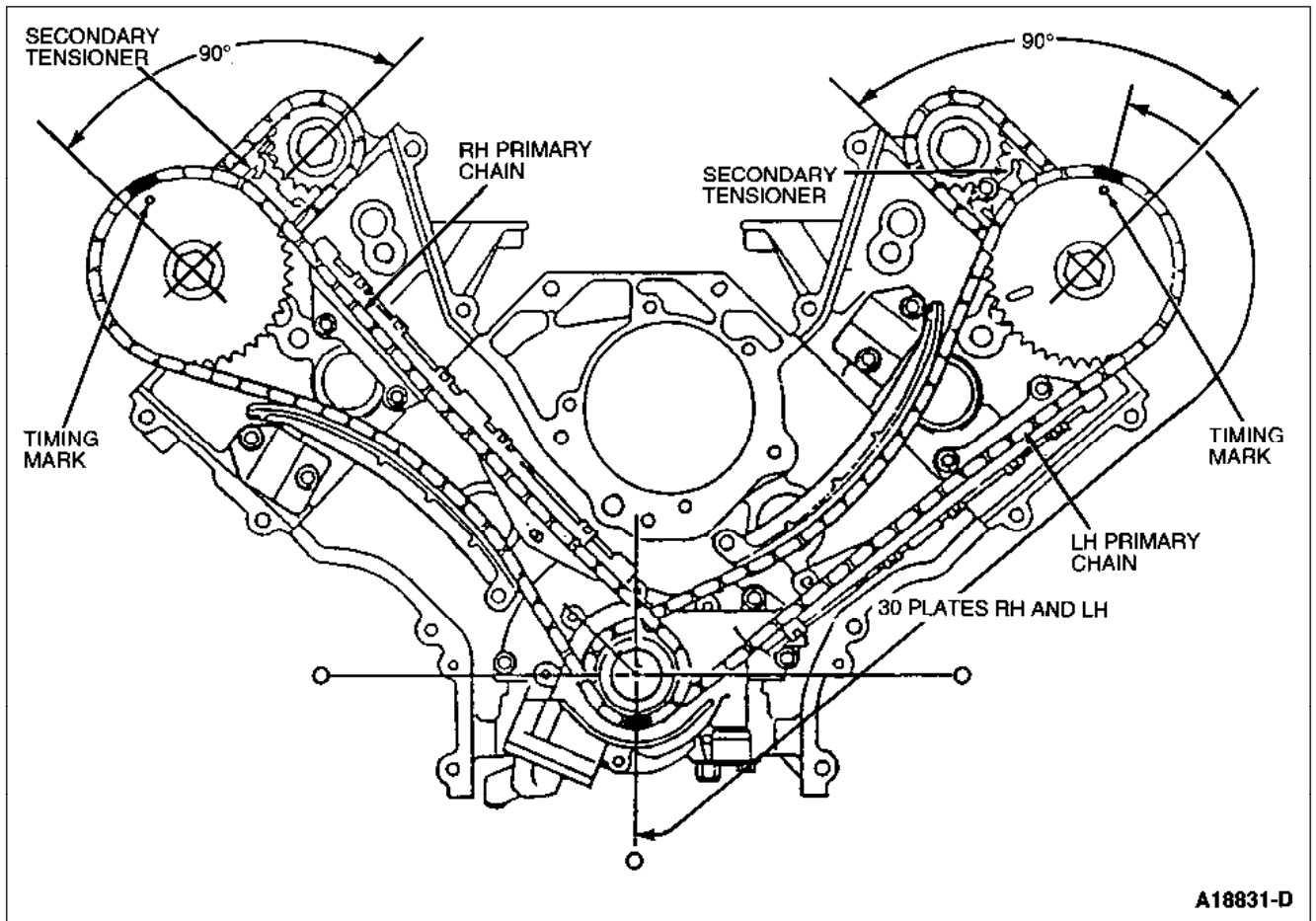

5. NOTE: To prevent accidental rotation of the camshafts and possible engine damage, install Camshaft Positioning Tool T93P-6256-A and Camshaft Holding Tool T93P-6256-AH.

Install Camshaft Positioning Tool T93P-6256-A in rear D-slots of both RH camshafts as shown.

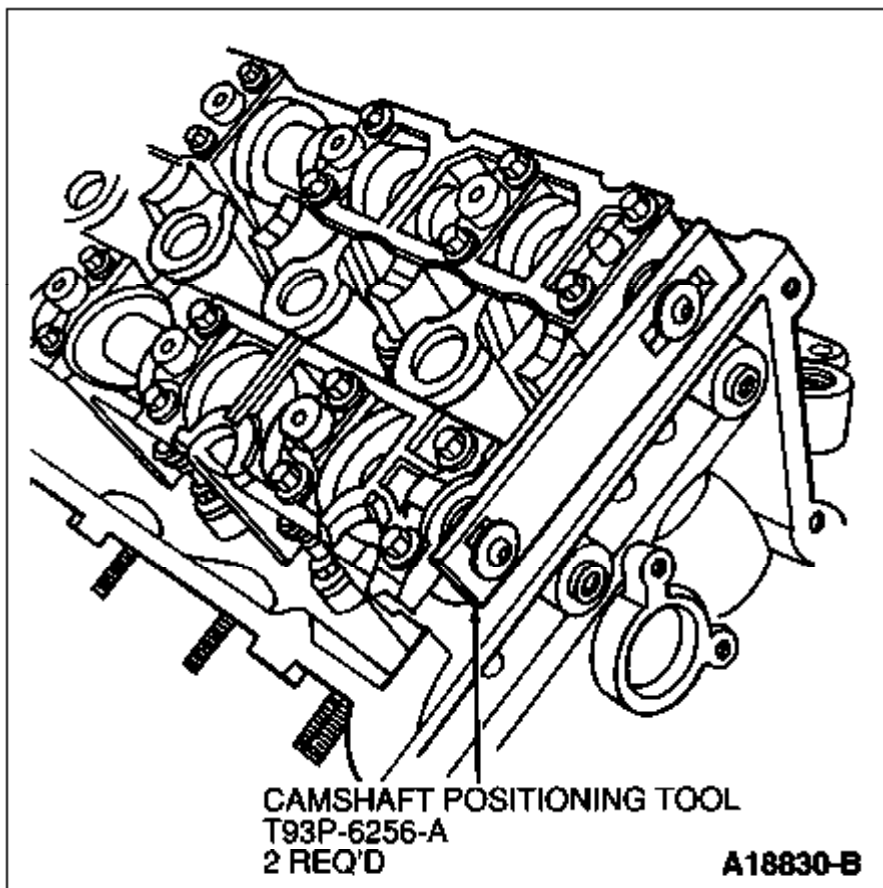

6. **CAUTION:** Failure to use Camshaft Holding Tool T93P-6256-AH while assembling or disassembling timing chains will result in damage to D-slots or Camshaft Positioning Tool T93P-6256-A.

Install Camshaft Holding Tool T93P-6256-AH onto RH camshafts as shown to keep camshafts from rotating and to prevent deformation of Camshaft Positioning Tool T93P-6256-A.

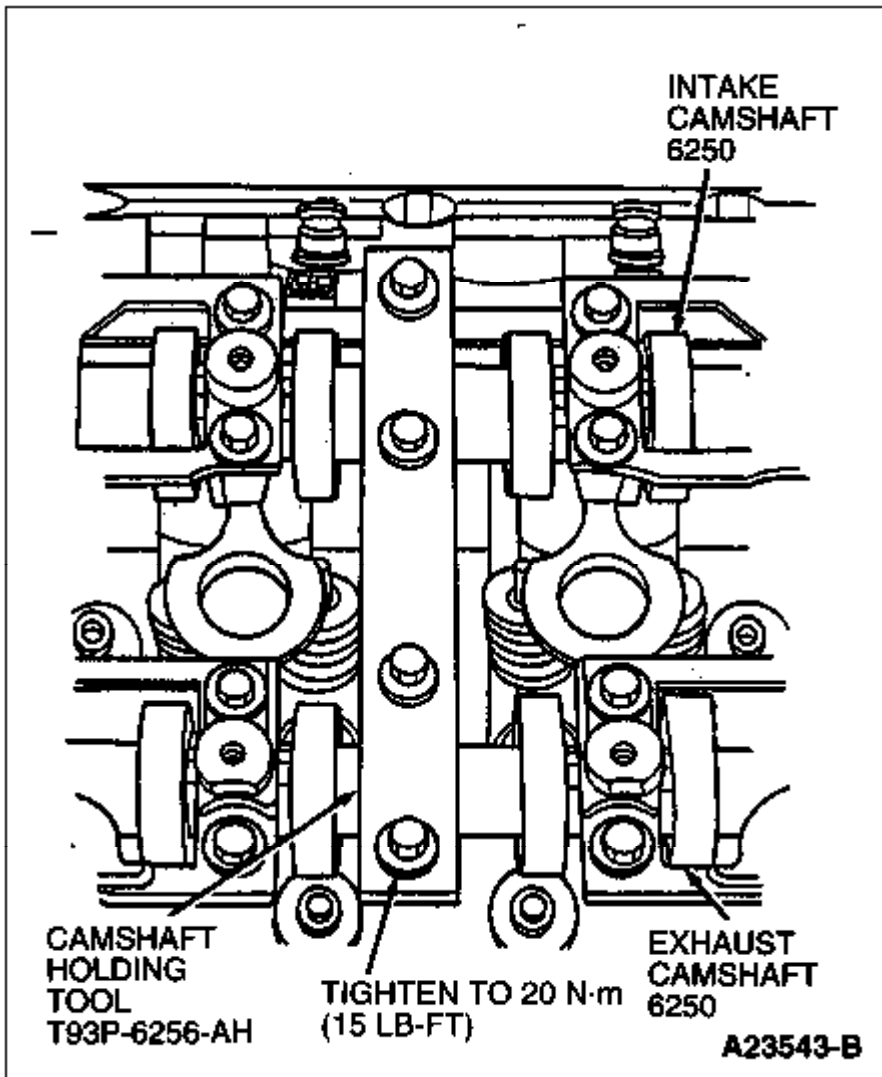

7. Remove two bolts retaining RH primary timing chain tensioner (6L266) to cylinder head and remove primary timing chain tensioner.

### Timing Chain Tensioner

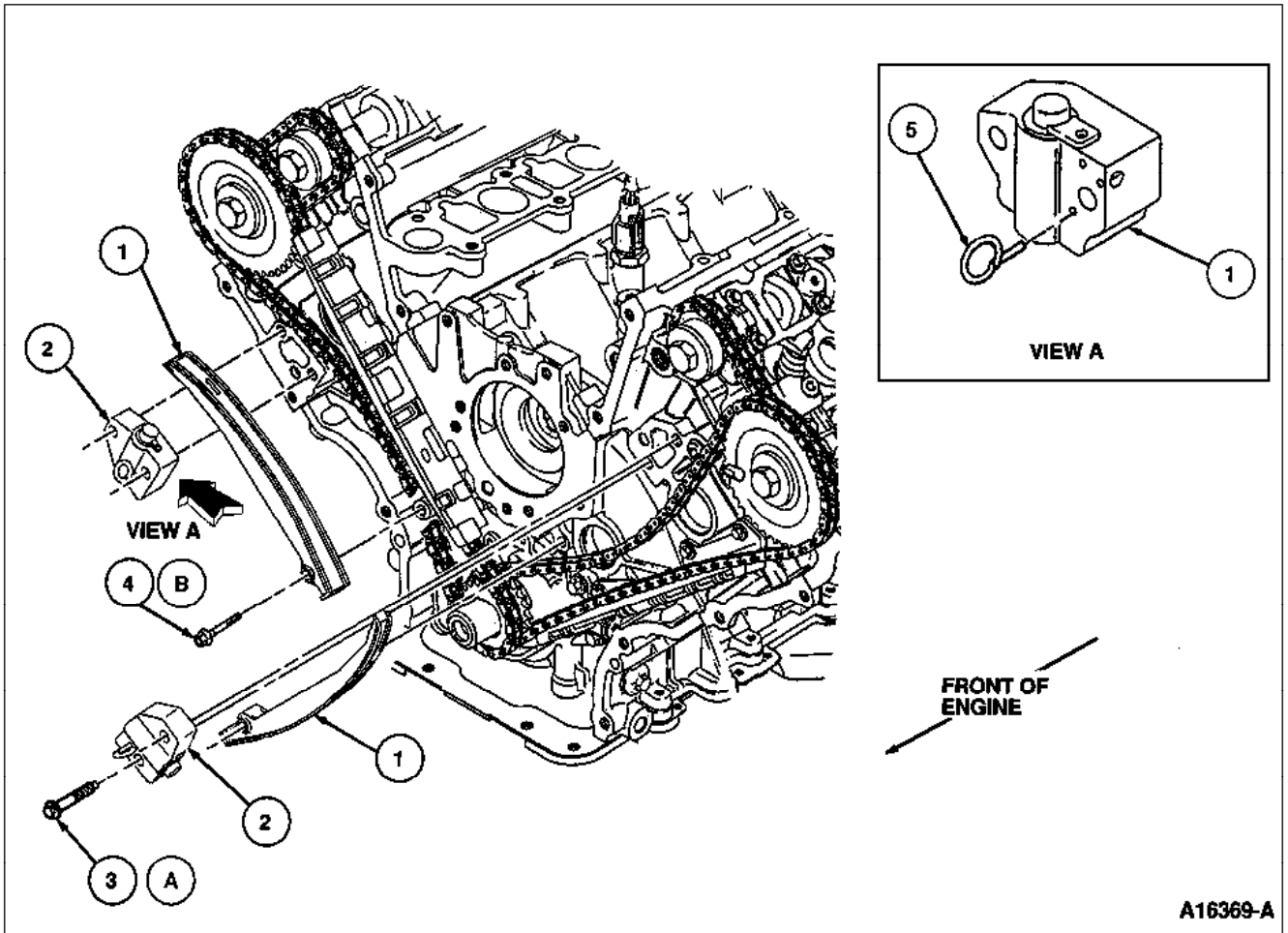

A16369-A

Item	Part Number	Description
1	6L253	Timing Chain Tensioner Arm (2 Req'd)
2	6L266	Timing Chain Tensioner (2 Req'd)
3	--	Bolt, Tensioner
4	--	Bolt, Tensioner Arm
5	--	Locking Pin
A	--	Tighten to 20-30 N-m (15-22 Lb-Ft)
B	--	Tighten to 10-15 N-m (7-11 Lb-Ft)

8. Remove bolt retaining RH timing chain tensioner arm (6L253) and remove timing chain tensioner arm.
9. NOTE: Two bolts retaining the timing chain guide (6K297) to the cylinder head are longer than the one to the cylinder block (6010).  
Remove three bolts retaining RH timing chain guide and remove timing chain guide.
10. NOTE: Do not loosen the camshaft sprocket bolts.  
Remove RH primary timing chain from camshaft sprocket.
11. Remove RH crankshaft sprocket (6306) and RH primary timing chain.
12. **CAUTION:** Failure to use Camshaft Holding Tool T93P-6256-AH while removing or

**tightening camshaft bolts may result in damage to camshaft D-slots or Camshaft Positioning Tool T93P-6256-A.**

If it is necessary to remove primary or secondary camshaft sprockets or secondary timing chain tensioners, install camshaft torquing tool at center area of camshafts.

13. **NOTE:** Camshaft Holding Tool T93P-6256-AH must be installed on camshafts to prevent camshafts from rotating.

Remove camshaft sprocket retaining bolts and primary camshaft sprocket.

14. **CAUTION: Secondary timing chain tensioner plunger is spring-loaded. Care must be taken to prevent plunger from dropping out of timing chain tensioner during disassembly.**

Compress secondary timing chain tensioners and lock the timing chain tensioner in the compressed position using clip. Remove secondary timing chain and camshaft sprockets.

15. Remove secondary timing chain tensioner.

16. **CAUTION: Failure to use camshaft holding tool while removing or tightening camshaft bolts may result in damage to camshaft D-slots or Camshaft Holding Tool T93P-6256-AH.**

Remove two bolts retaining LH primary timing chain tensioner to cylinder head and remove primary timing chain tensioners

17. Remove bolt retaining LH timing chain tensioner arm and remove LH timing chain tensioner arm.

18. Remove three bolts retaining LH timing chain guide and remove timing chain guide.

19. Remove LH primary timing chain from camshaft sprocket and crankshaft sprocket.

20. If necessary, remove primary or secondary camshaft sprockets or secondary timing chain tensioners with Camshaft Holding Tool T93P-6256-AH at center area of camshafts.

21. Remove camshaft sprocket retaining bolts.

22. **CAUTION: Secondary timing chain tensioner plunger is spring-loaded. Care must be taken to prevent plunger from dropping out of timing chain tensioner during disassembly.**

Compress secondary chain tensioner and lock the chain tensioner in the compressed position using clip. Remove secondary timing chain and camshaft sprockets.

23. **CAUTION: Do not rotate crankshaft and/or camshafts or engine damage may occur.**

**NOTE:** Camshaft Holding Tool T93P-6256-AH and Camshaft Positioning Tool T93P-6256-A must be installed on camshafts to prevent camshafts from rotating.

Inspect friction material on timing chain tensioner arms and timing chain guides. If worn or damaged, remove and clean oil pan (6675) and replace oil pump screen cover and tube (6622).

## Installation

1. **NOTE:** If engine has jumped time, make sure that all services to engine components and/or valve train has been made.

**NOTE:** Make sure primary and secondary timing chain tensioners are in collapsed position and retained with clip.

If cylinder head was removed from cylinder block, position crankshaft keyway to 270 degrees (or at nine o'clock position).

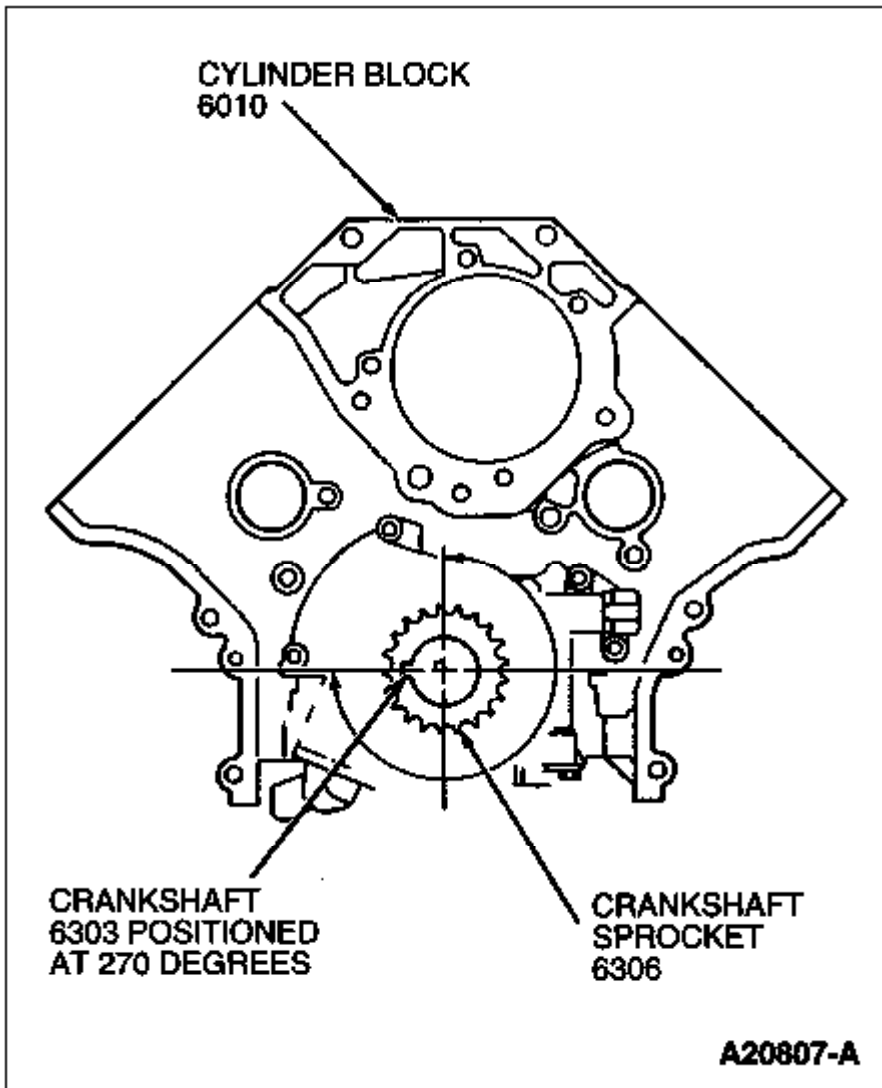

2. NOTE: The rocker arms must not be installed in the cylinder heads at this time.  
Install cylinder heads on cylinder block as outlined.
3. Install Camshaft Positioning Tool T93P-6256-A into D-slots on rear of camshafts to position both intake and exhaust camshafts with the keyways pointing down towards crankshaft.

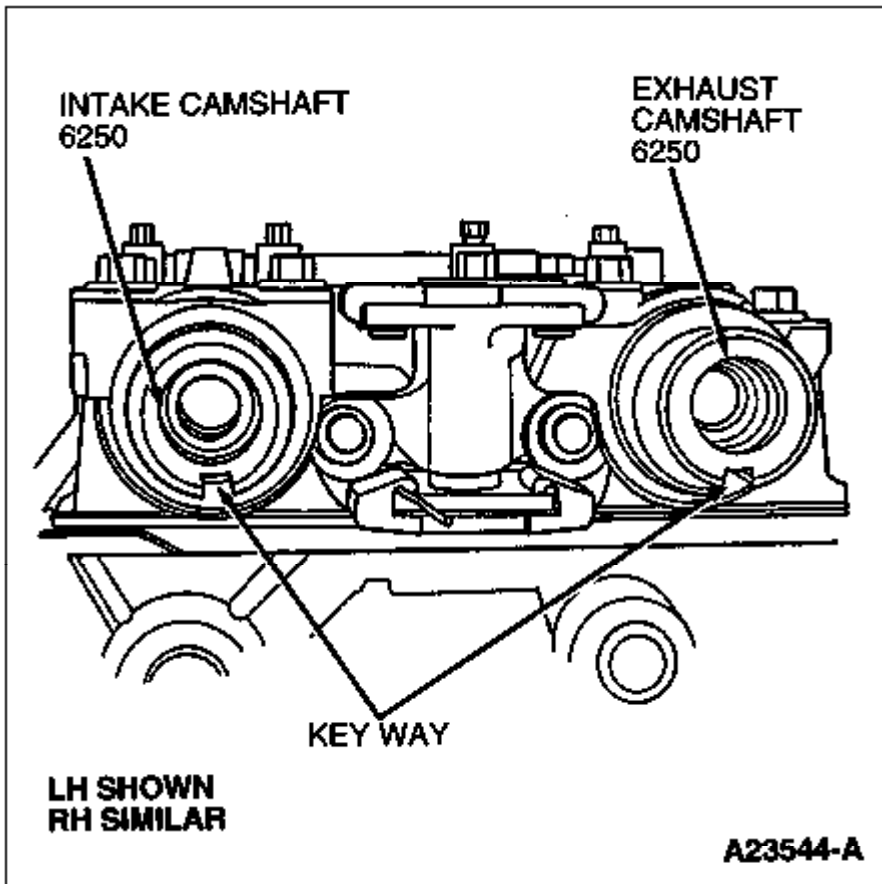

4. NOTE: Do not remove Camshaft Holding Tool T93P-6256-AH from camshafts until all parts are installed and tightened.  
  
Install Camshaft Holding Tool T93P-6256-AH on center of camshafts.
5. If removed, install LH secondary timing chain tensioner. Tighten retaining bolts to 8-12 N-m (70-106 lb-in).
6. If removed, install LH secondary camshaft sprockets and secondary timing chain as an assembly with hubs of camshaft sprockets facing as shown in the following illustration.

### Secondary Timing Chains

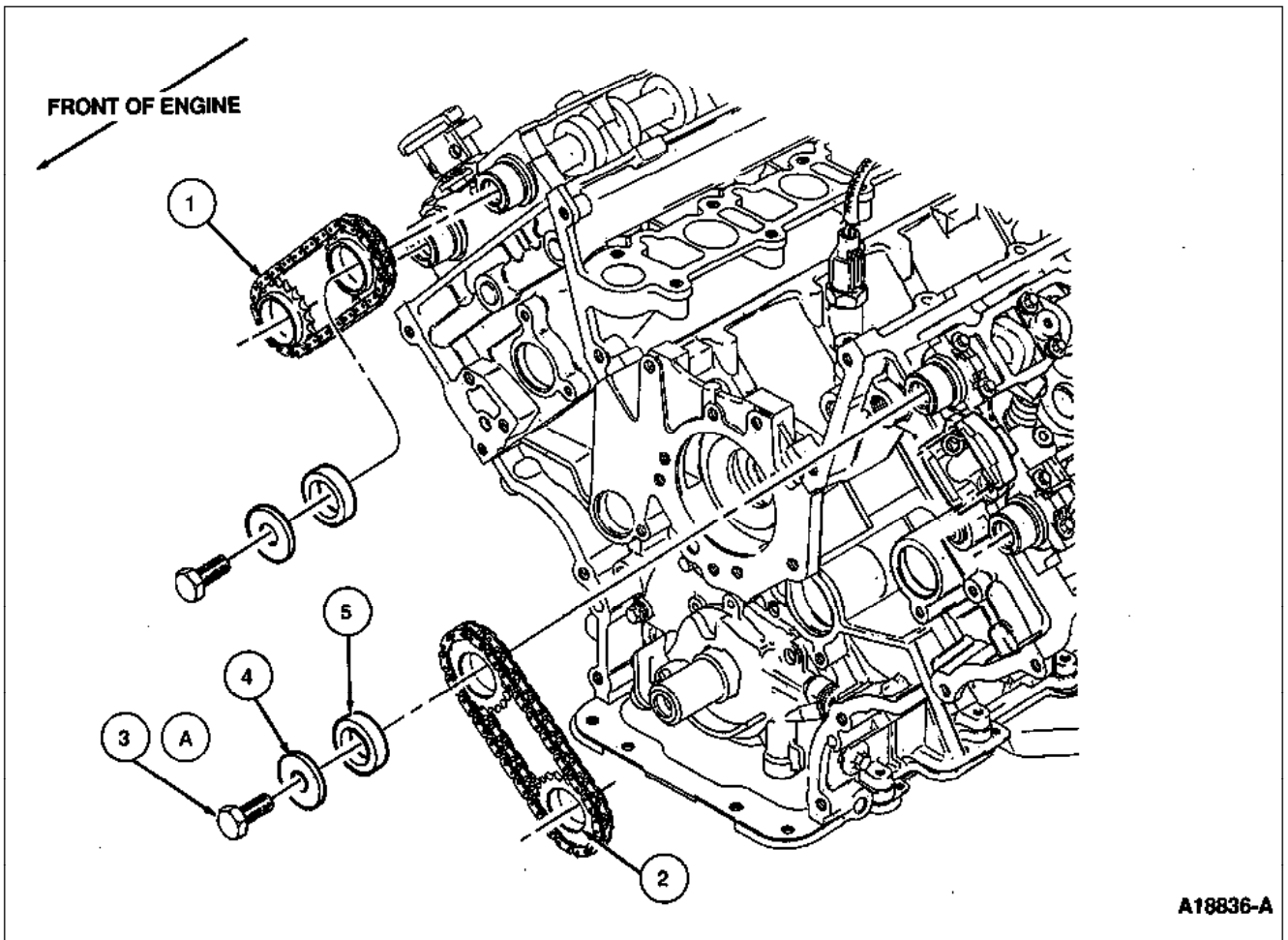

Item	Part Number	Description
1	6268	Timing Chain (2 Req'd)
2	2656	Secondary Camshaft Sprocket (4 Req'd)
3	N806139	Camshaft Sprocket Retaining Bolt (2 Req'd)
4	N806164	Washer (2 Req'd)
5	6265	Camshaft Sprocket Spacer (2 Req'd)
A	--	Tighten to 110-130 N-m (81-95 Lb-Ft)

7. Remove locking pin from secondary timing chain tensioner
8. Install LH primary camshaft sprocket and camshaft sprocket spacer (6265) on LH camshaft.
9. NOTE: Secondary camshaft sprockets must be free to turn.  
Install washers and camshaft sprocket retaining bolts. Tighten with fingers only.
10. Install Timing Chain Tensioning Tool T93P-6256-BH on LH secondary timing chain tensioner

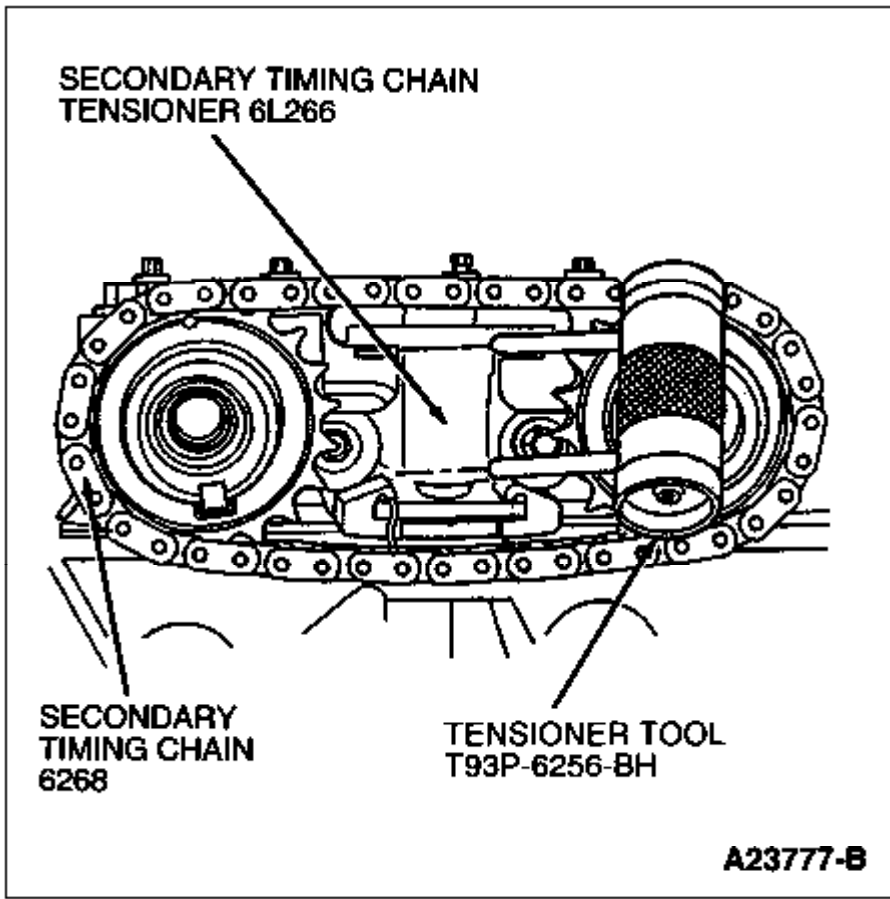

11. **CAUTION:** Failure to use Camshaft Holding Tool T93P-6256-AH while assembling or disassembling timing chains will result in damage to D-slots or Camshaft Positioning Tool T93P-6256-A.

Install Camshaft Positioning Tool T93P-6265-A into D-slots.

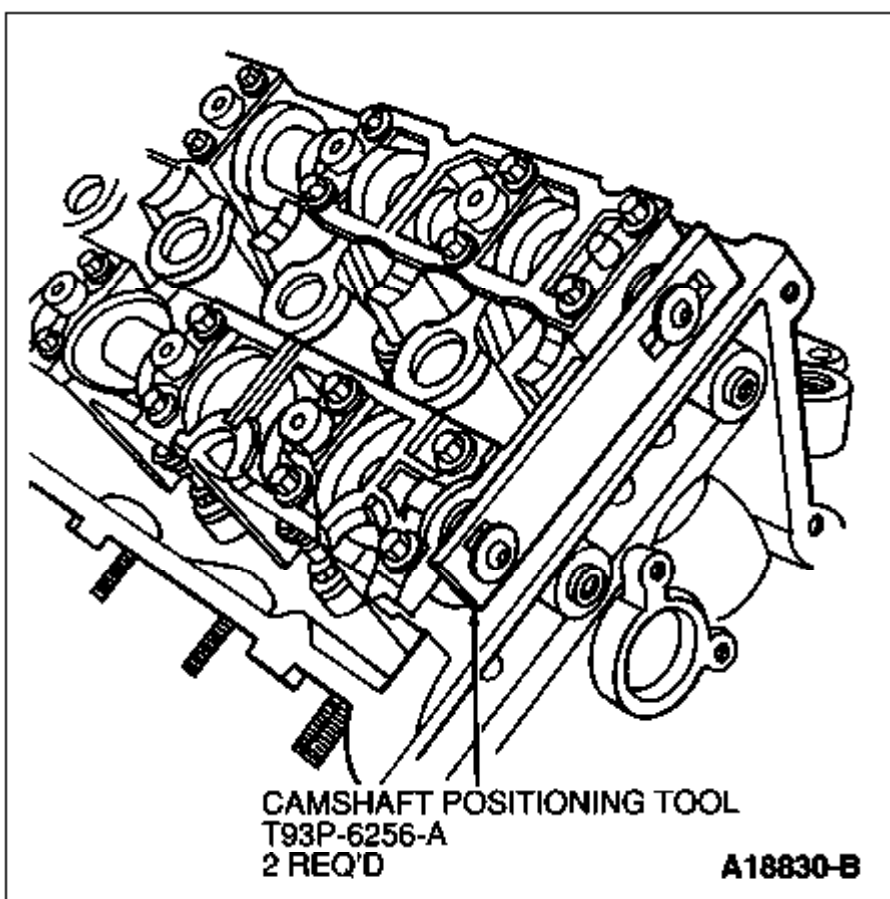

12. Install Camshaft Holding Tool T93P-6256-AH at center area of LH intake and exhaust camshafts.
13. Tighten camshaft sprocket bolts to 110-130 N-m (81-95 lb-ft).
14. NOTE: Remove Camshaft Positioning Tool and Camshaft Holding Tool.

Repeat Steps 1 through 13 for RH cylinder head.

15. NOTE: Crankshaft sprockets are identical. They may only be installed one way. Refer to the following illustration for proper crankshaft sprockets installation.

Install LH crankshaft sprocket.

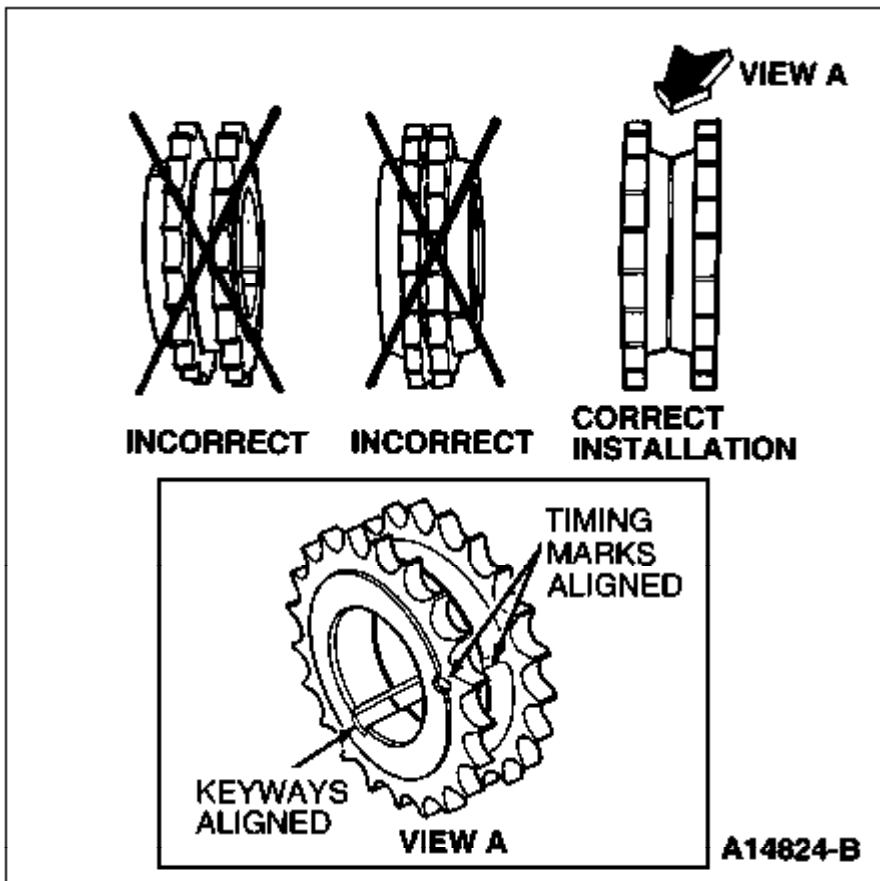

16. NOTE: Make sure tapered part of crankshaft sprocket faces away from cylinder block for LH primary timing chain crankshaft sprocket.

NOTE: If colored links of timing chain are not visible, split both chains in half and mark the two opposing links as shown.

Install LH primary timing chain on LH primary camshaft sprocket. Make sure marked link of timing chain lines up with timing mark of camshaft sprocket.

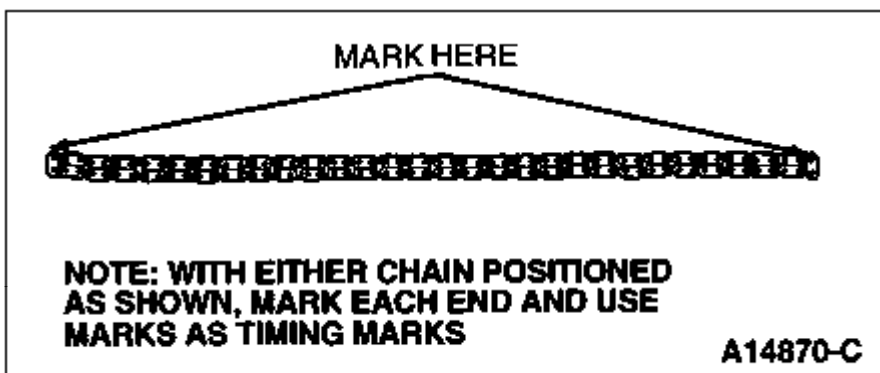

17. Install LH primary timing chain on crankshaft sprocket. Make sure marked link of timing chain lines up with timing mark of crankshaft sprocket.
18. NOTE: Make sure tapered part of crankshaft sprocket faces toward cylinder block for RH primary timing chain crankshaft sprocket.

Repeat Steps 14, 15 and 16 for RH primary timing chain.

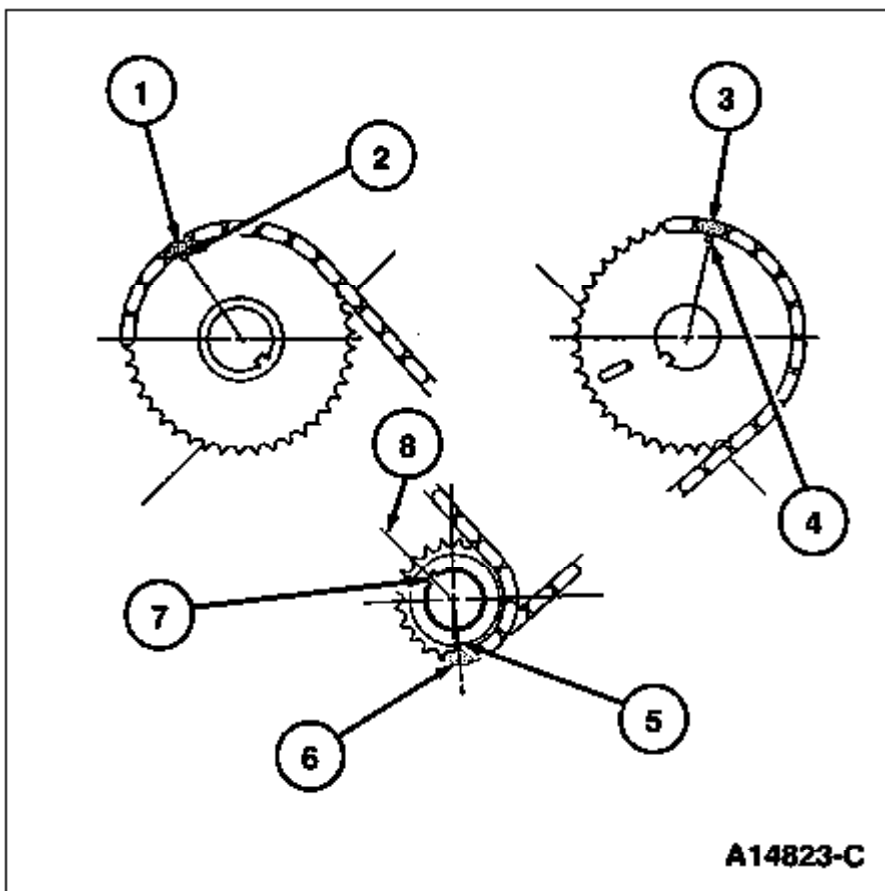

Item	Part Number	Description
1	--	RH Camshaft Timing Chain Mark
2	--	RH Camshaft Sprocket Mark
3	--	LH Camshaft Timing Chain Mark
4	--	RH Camshaft Sprocket Mark
5	--	Camshaft Sprocket Mark
6	--	Crankshaft Timing Chain Mark
7	6303	Crankshaft
8	--	Crankshaft Keyway Center Line

19. NOTE: For timing chain guides, two bolts to the cylinder head are longer than the bolt to the cylinder block.

Install RH and LH timing chain guides and secure with three bolts on each. Tighten bolts to 8-12 N-m (71-106 lb-in).

## Timing Chain Guide

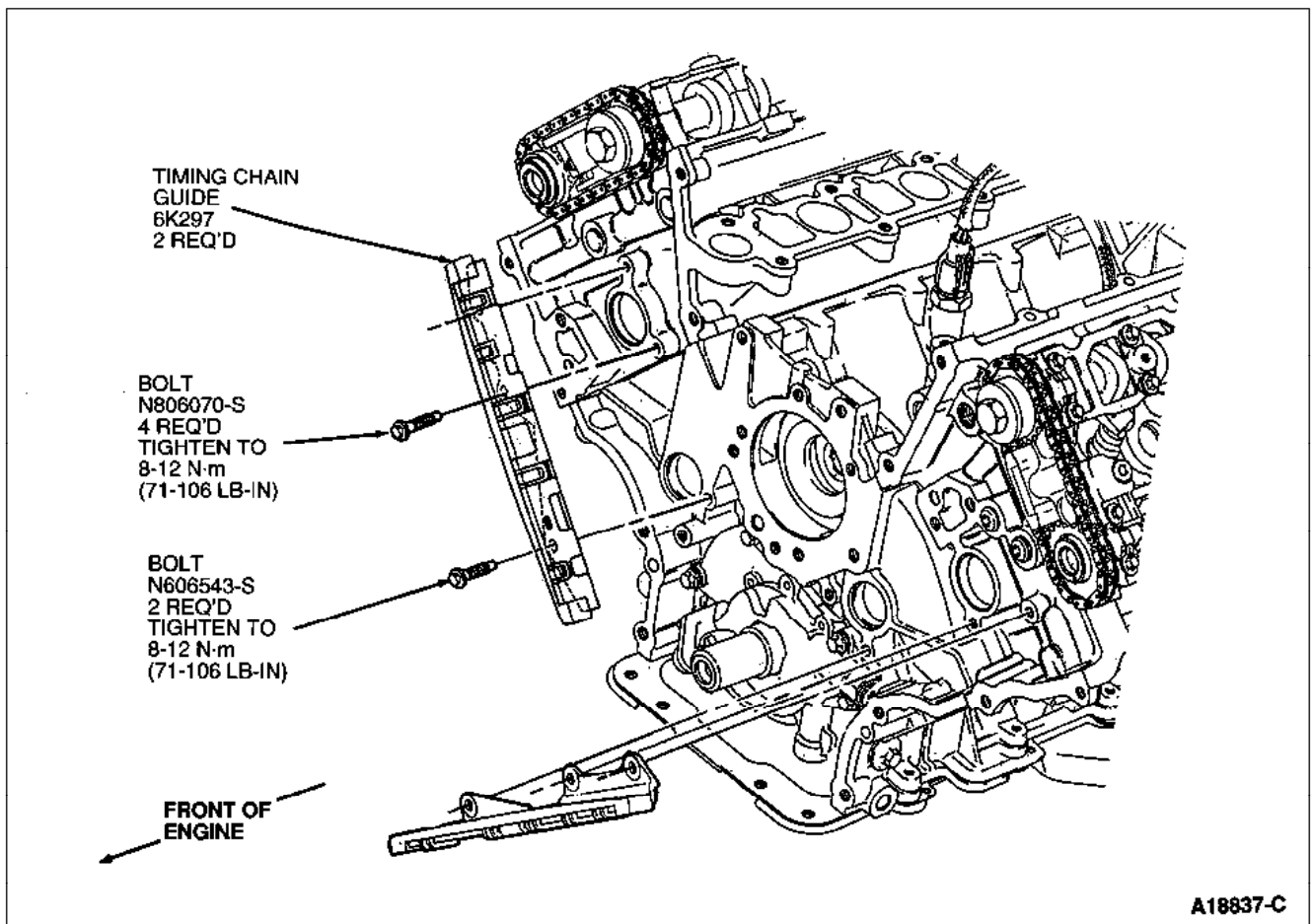

20. Lubricate timing chain tensioner arm contact surfaces with engine oil meeting Ford specification ESE-M2C153-E and install RH and LH timing chain tensioner arms using one bolt each. Tighten to 10-15 N·m (7-11 lb-ft).
21. Unlock the primary tensioner ratcheting device (using a small pick or similar tool, hold ratchet lock mechanism away from ratchet stem).
22. **CAUTION: Tensioner must be compressed slowly or rupture of tensioner body casting will result from excessive hydraulic pressure. Failure to release ratchet lock mechanism while compressing piston will result in ratchet damage.**  
Slowly compress primary tensioner piston in small increments with minimal force.
23. Lock the primary tensioner ratcheting device with a small pin (paper clip) once the tensioner is fully compressed and the ratchet stem is flush to the tensioner body.

## Timing Chain Tensioner

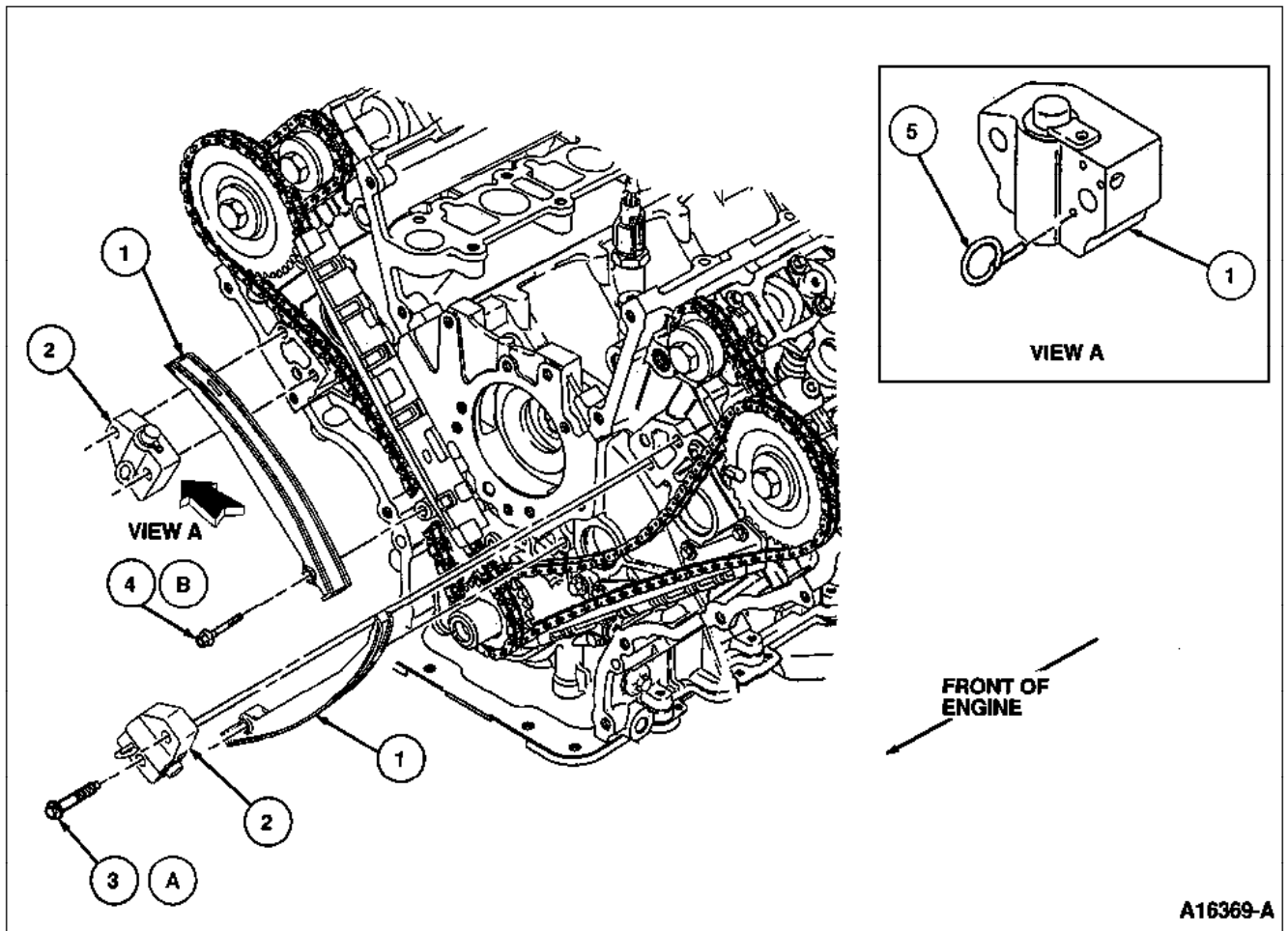

A16369-A

Item	Part Number	Description
1	6L253	Timing Chain Tensioner Arm (2 Req'd)
2	6L266	Timing Chain Tensioner (2 Req'd)
3	--	Bolt, Tensioner
4	--	Bolt, Tensioner Arm
5	--	Locking Pin
A	--	Tighten to 20-30 N-m (15-22 Lb-Ft)
B	--	Tighten to 10-15 N-m (7-11 Lb-Ft)

24. NOTE: Do not remove lock pins until timing chain guides are installed.

Install RH and LH primary timing chain tensioners and secure with two bolts on each. Tighten bolts to 20-30 N-m (15-22 lb-ft).

25. Remove lock pins from primary timing chain tensioners and make sure all timing marks are aligned.

26. Install crankshaft position sensor pulse wheel with hub facing crankshaft sprocket.

27. Install rocker arms as outlined.

28. NOTE: When cleaning sealing surfaces of the engine front cover and oil pan-to-cylinder block joints, use extreme caution not to damage the rubber bead of the oil pan gasket (6710). If a leak should occur upon reassembly, remove the oil pan and replace the oil pan gasket.

Install engine front cover as outlined.

29. Start engine and check for leaks and proper operation.

---